

See discussions, stats, and author profiles for this publication at: <https://www.researchgate.net/publication/333402623>

# CONFIGURING OF 3 AXIS MINI CNC MACHINE TOOL WITH CONTROL SYSTEM BASED ON LINUXCNC

Conference Paper · May 2019

CITATIONS

3

READS

2,224

4 authors:



**Sasa Zivanovic**  
University of Belgrade

82 PUBLICATIONS 450 CITATIONS

SEE PROFILE



**Zoran Dimic**  
Lola Institut

46 PUBLICATIONS 206 CITATIONS

SEE PROFILE



**Vorkapic Nikola**  
University of Belgrade

16 PUBLICATIONS 40 CITATIONS

SEE PROFILE



**Stefan Mitrovic**  
Lola Institut

15 PUBLICATIONS 55 CITATIONS

SEE PROFILE

Some of the authors of this publication are also working on these related projects:



3-axis parallel kinematic machines - MIS.3.02.0101.B [View project](#)



Integrisana istraživanja u oblasti makro, mikro i nano mašinskog inženjerstva- podprojekat TR35022 -Razvoj nove generacije domaćih obradnih sistema [View project](#)



## CONFIGURING OF 3 AXIS MINI CNC MACHINE TOOL WITH CONTROL SYSTEM BASED ON LINUXCNC

Zivanovic Sasa<sup>1</sup>, Dimic Zoran<sup>2</sup>, Vorkapic Nikola<sup>3</sup>, Mitrovic Stefan<sup>4</sup>

**Summary:** *In this paper, a mini CNC machine tool with three translational axis and open-architecture control system is being considered. Existing CAD/CAM software environment was used in order to create adequate corresponding virtual machine and to enable CNC program development and testing for the specific platform. Prototype of the machine was made utilizing parts salvaged from multiple CD/DVD drives. Control system hardware is realized in two ways: based on PC platform and based on Raspberry Pi 3B+, while the software part uses open-architecture LinuxCNC. Experiments were performed in order to verify proper functioning of the entire system.*

**Key words:** *mini CNC, CAD/CAM, virtual prototype, simulation, control, LinuxCNC, open architecture control*

### 1. INTRODUCTION

Modern production is based on CNC machine tools and such production demands highly skilled workforce. Skills needed for proper CNC utilization are taught in various courses at secondary schools, faculties and specialized organizations [1,2]. Additionally, further development of small and medium-sized enterprises relies heavily on the use of CNC machine tools. Since procurement of CNC machine tools can be seen as a form of capital investment, in order to bridge the economic gap, many small enterprises opt for modernization or revitalization of their existing machines by using low-cost variants of CNC controllers, among which the most notable one is LinuxCNC – obtainable free of charge, fully customizable for target hardware and open-source [3]. This paper takes into consideration problems related to proper CNC operator education and demonstrates specific implementation of the open-architecture control system on self-constructed 3-axis mini CNC machine.

The CNC machine tool presented in this paper is primarily an educational machine and can be made with readily available, low-cost components and single

---

<sup>1</sup>Dr Sasa Zivanovic, associate professor, University of Belgrade, Faculty of Mechanical Engineering, (szivanovic@mas.bg.ac.rs) (CA)

<sup>2</sup>Dr Zoran Dimic, LOLA Institute, (zoran.dimic@li.rs)

<sup>3</sup>Nikola Vorkapic, assistant, University of Belgrade, Faculty of Mechanical Engineering, (nvorkapic@mas.bg.ac.rs)

<sup>4</sup>Stefan Mitrovic, assistant, LOLA Institute, (stefan.mitrovic@li.rs)

compatible computer, acting as a host for CNC software. Proposed machine is controlled using open-architecture LinuxCNC software which has proven itself in numerous occasions as an acceptable alternative to available industrial-grade solutions. Programming of machining operations is done through utilization of G code and it does not differ from usual practice that is already established in the field. As a consequence, proposed mini CNC machine can be a fully functional part of an educational system [1] and eliminates the problems which potential equipment procurement incurs. Significant investments are circumvented since the machine can be easily replicated, enabling every candidate enrolled in a course to work with a personal, dedicated machine. Educational machines are in high demand and a large number of secondary schools and faculties face troubles obtaining such specialized equipment. Institutions in Serbia most frequently procure educational CNC machines through EMCO Education Ltd, while other big bidders of such systems are Roland DG Corporation, The Cool Tool, Renishaw etc.

Currently, CNC training is usually performed in groups on a single CNC machine, which oftentimes lowers the overall quality of the training due to the availability issues. If the CNC machine is not available, training is reduced to program verification using the CNC simulator, leaving the trainee with no experience in using a real CNC machine. The machine proposed in this work can be easily replicated in large quantities with very low price per unit, thus enabling the concept of a single trainee per CNC machine.

Further development of open architecture control systems should provide appropriate level of flexibility, modularity and adaptability of interfaces that is required by new machine tools.

In chapter 2 of this paper, existing mini CNC machines based on CD/DVD drive hardware are presented and analyzed. Proposed mini CNC machine tool is presented in chapter 3, which includes the development of a virtual prototype in CAD/CAM environment, simulation of working virtual prototype according to the given program (G code) and physical realization of the machine. Chapter 4 describes the implemented machine control system, while chapter 5 shows the experimental trial of the machine and tests the control system by drawing a large number of programmed contours.

The expected efficiency and quality of human work correlated with modern CNC machine tools can be achieved by applying a high quality educational system. The system must provide adequate learning environment and output individuals with levels of knowledge and skill that are satisfactory in order to correctly utilize the potential of CNC machines. Proposed mini CNC represents a utility that could usher in the future high-quality educational system for CNC operators.

## **2. MINI CNC MACHINE TOOLS**

Mini CNC machine tools based on CD/DVD drive hardware are usually self-constructed machines, but there are also commercial solutions on the market. These machines are commonly used as mini CNC plotters that draw programmed contours, or as laser engraving machines and mini 3D printers. Figure 1 gives an overview of the selected solutions for such machines, presented in several categories:

1. 2 axis mini CNC machine tools for laser engraving (Fig.1a,b,c),
2. 2 ½ axis mini CNC machine tools for draw programmed contours (Fig.1d,e),
3. mini CNC 3D printer (Fig.1f)
4. 3-axis mini CNC machine tools to draw programmed contours (Fig.1g-l).

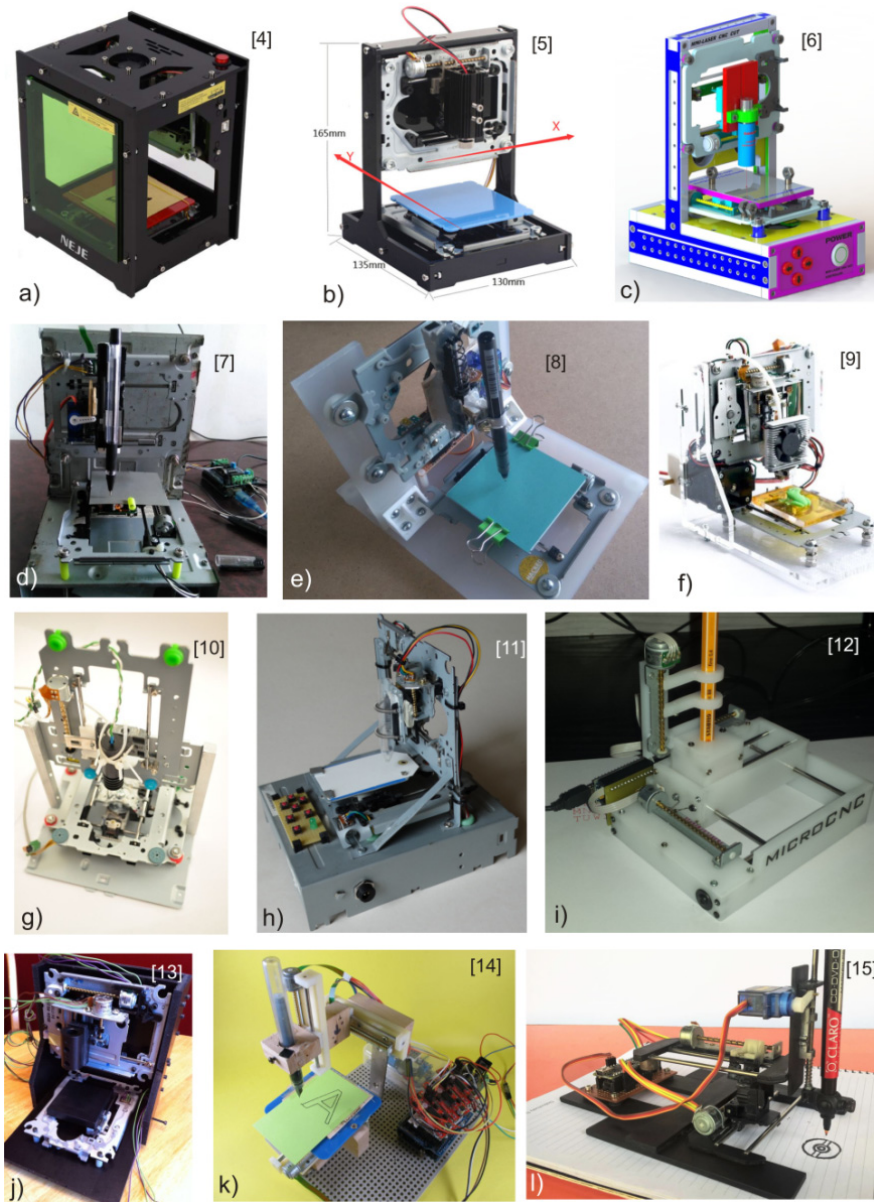

Fig. 1 Mini CNC machine tools based on CD/DVD drive hardware [4-15]

The first group of mini CNC machine tools for laser engraving have two numerically controlled axes (Fig.1a,b,c). The first two of them from (Fig.1a,b) are commercial solutions of mini CNC machine tools for laser engraving.

The machine shown on Fig.1c was entirely 3D printed with all of its components. The second group of 2 ½ axes mini CNC machine tools has X and Y axis which use CD/DVD drive hardware, but the Z axis uses a simple motor for lowering and raising of

the pen (positional axis). Fig.1f shows a mini 3D printer. Other machines from the fourth group have 3 axes and CD/DVD drive components were utilized for all of them. Main differences between mentioned solutions occur in their mechanical structure and the axis arrangement. The simplest solutions used metal housings of the CD/DVD drives as the structure that carries the drive axes (Fig1.d,g,h). Very often, structural parts are made with 3D printer or out of wood or plastic (Fig.1e,f,i,j,k,l).

If you analyze the kinematics of these machines, most of them have one Degree-of-Freedom (DoF) for the workpiece and two DoF for the tool. Solutions where all three movements (X, Y, Z) are done by the tool are possible, in which case, the workpiece is fixed (Fig1. i,l).

In this paper, a 3-axis mini CNC machine tool with kinematic structure X'OYZ is selected for realization. Drawing pen is fixed along the Z-axis. Special Z-axis laser module is planned in order to use the machine for engraving. LinuxCNC open-architecture software system is used for machine control.

### **3. CONFIGURING OF THE 3-AXIS MINI CNC MACHINE TOOL**

Development of the machine was led by the idea that the hardware found in obsolete CD/DVD drives is enough for the realization of the 3-axis mini CNC machine. Geometric and kinematic parameters of the machine are dictated by the constraints of the hardware salvaged from the CD/DVD drives, resulting in a relatively small, cube-shaped workspace of 35x35x35 mm. As mentioned, accepted kinematic structure of the machine was X'OYZ. The worktable is moving along the X'-axis and the slider is moving on the Y-axis while carrying the Z-axis.

Basic configuration requirements are as follows: (i) low-cost mini CNC machine tool, (ii) laboratory and education suitable, (iii) performs pen drawing or laser engraving, (iv) implements open-architecture based control, (v) G code programmable.

The following describes the phase prior to the adoption of the final structural design and the ensuing configuration of the virtual prototype in the CAD/CAM environment. Developed virtual prototype later served for the initial manufacturing program verification within a machining simulation.

#### **3.1 CONFIGURING OF THE VIRTUAL PROTOTYPE**

For the configuration of the virtual prototype, CAD/CAM system PTC Creo [16] was selected. All the components, along with the main assembly of the machine, were modelled in PTC Creo. Developed virtual prototype with marked coordinate axes, workspace and the components of the drive are shown in Fig.2.

For the X-axis and Y-axis the complete drives and guides of CD/DVD hardware were used. For Z-axis, some modifications were necessary, in accordance with the available space. The base structure connects all the drives and forms a complete mechanical system. The example assembly and assembly drawing views of the mini CNC machine tool are shown in Fig. 3.

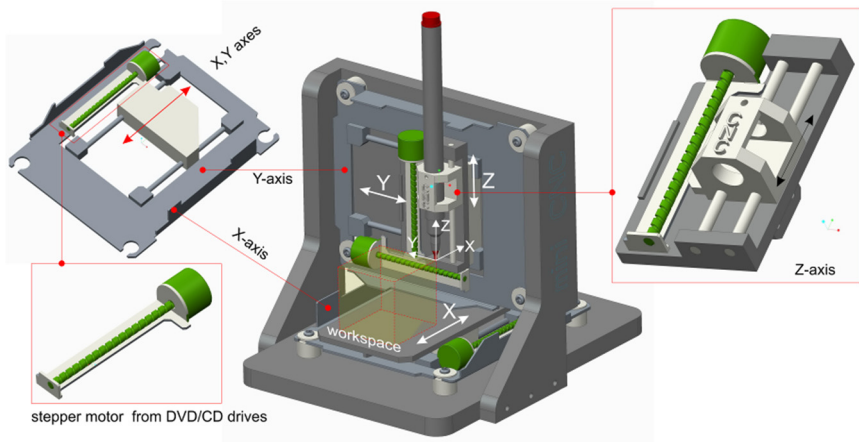

Fig. 2 CAD model of the table 3-axis mini CNC machine tool with basic components

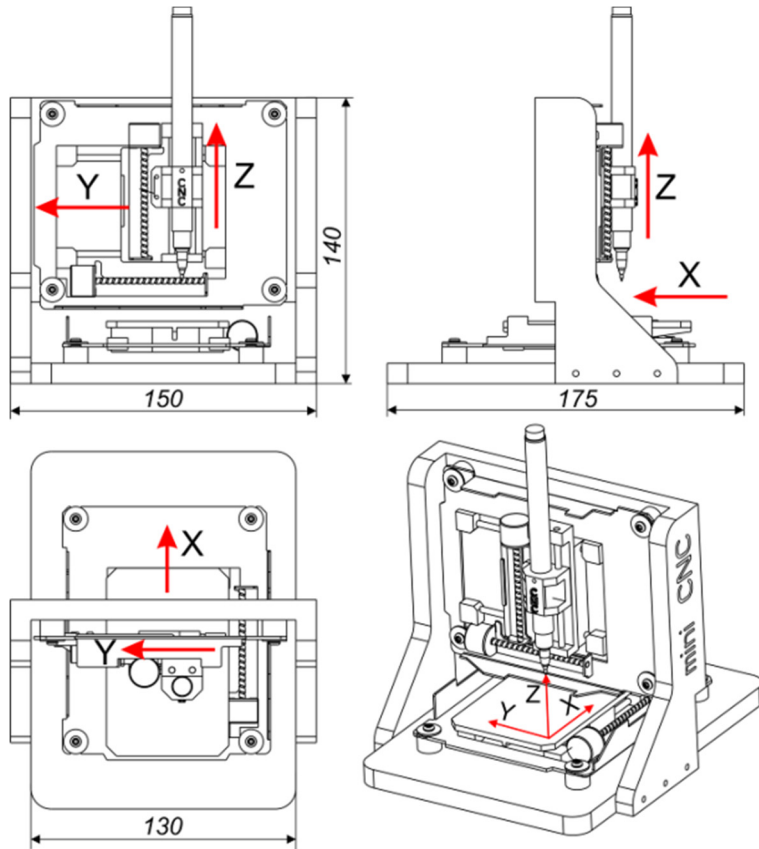

Fig. 3 Drawing views of the complete assembly

### 3.2 SIMULATION OF THE VIRTUAL PROTOTYPE IN CAD/CAM SYSTEM

In order to generate virtual model adequate for simulation within designated CAD/CAM system, it was necessary to define corresponding kinematic connections between machine's moving elements. Examples of mentioned simulations can be found in papers [17,18]. PTC Creo software system supports all stages of the modelling and simulation that were needed for the development of our virtual model. The stages are as follows: (i) modelling the mechanism with defined kinematic connections, (ii) definition of restrictions in kinematic connections, (iii) manual interactive inspection of defined virtual kinematic connections, (iv) creating a video file of the moving virtual mechanism. Within the used software, kinematic connections of the considered machine were generated by applying a *Slider* connection type for translational movements of all 3 axes and defining corresponding movement limits of each individual axis. Programming of the considered machine is fairly straightforward, since it is a 2D plotting machine. Using the two-axis trajectory milling strategy without compensation of tool radius proved to be a simple and effective solution. Tool radius is unnecessary since, in this case, the tool is a pen and its tip is considered to be a point. Developed virtual machine during simulation of a drawing operation (defined in CLF format) is shown in Fig.4. In order to run the simulation, complete virtual model of the machine prototype is loaded. Machining program, defined in CLF format, is supplied and the simulation is run. If the simulated machining program is successfully verified, the CLF program is then postprocessed into adequate G code format. Machining program that was used in the simulation shown in Fig.4. incorporates contours of the coat of arms of the Republic of Serbia. Prepared DXF file containing the target contour is loaded in the PTC Creo environment and through standard CAD/CAM workflow, machining program (designated for drawing) is generated using the 2D trajectory milling strategy.

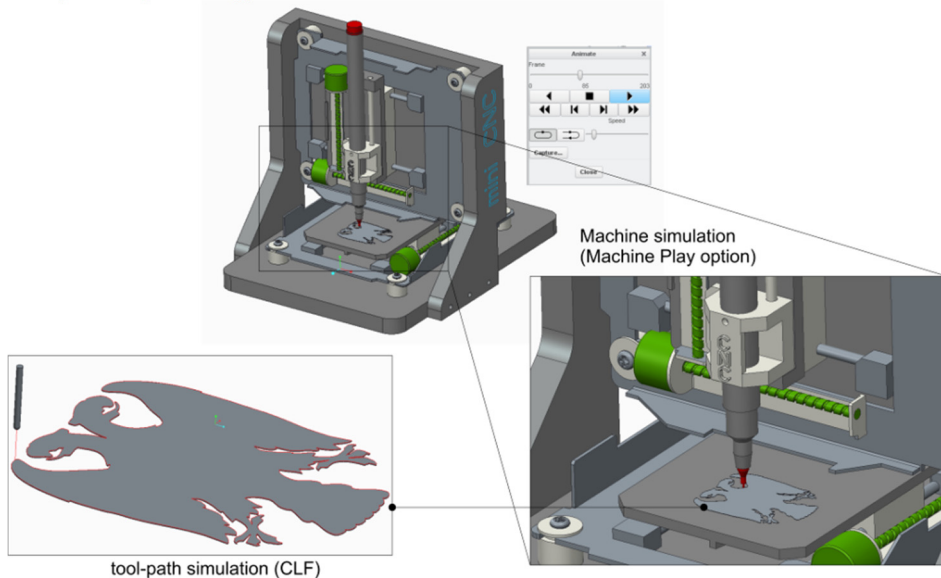
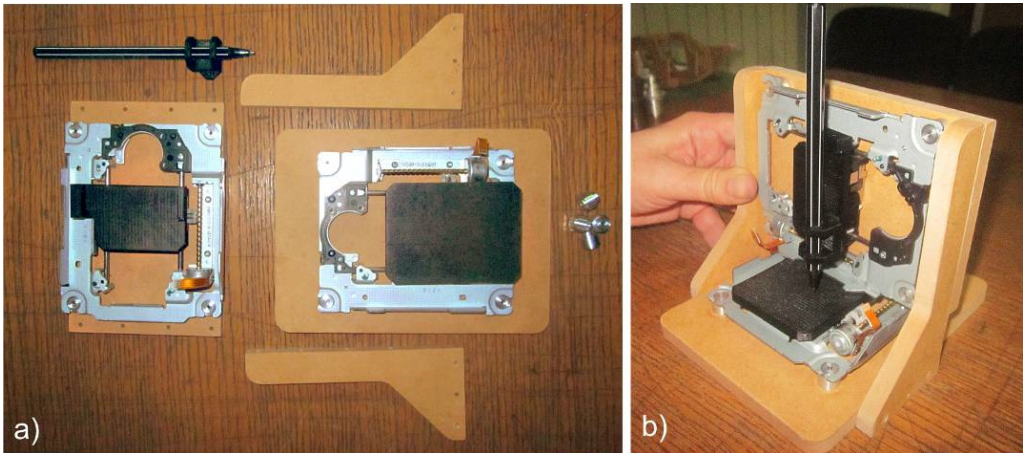

Fig. 4 Example of the simulation within the CAD/CAM environment with active virtual machine executing the given machining program (CLF)

### **3.3 REALIZATION OF THE PROTOTYPE**

In this chapter, some characteristic details about activities involved in realization of the prototype are given, such as: (i) production of the base structure from MDF(Medium-density fibreboard) board, on which the drives of X-axis and Y-axis are placed; (ii) production of the slider for the X-axis worktable and Y-axis slider by means of 3D printing; (iii) production of the 3D printed Z-axis slider; (iv) preparation of the pen which will be inserted as a tool inside the holder mounted on Z-axis. All components prepared for the machine are shown in Fig.5a, while the initial assembly is shown in Fig.5b.



*Fig. 5 Prepared components before assembly (a) and initial assembly (b)*

Fully assembled, mechanically complete prototype is shown in Fig.6. The next chapter covers the installation of the machine control system.

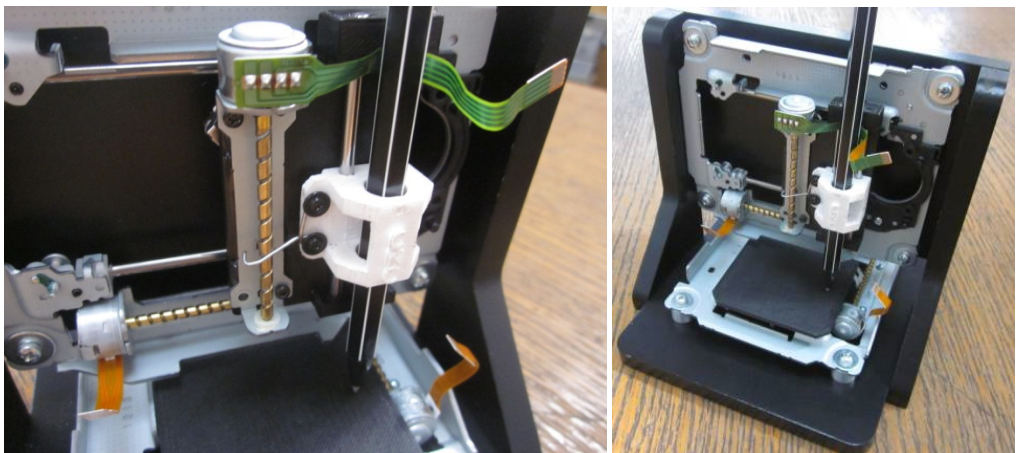

*Fig. 6 Fully assembled prototype of the machine*



#### 4. LINUXCNC CONFIGURATION FOR THE MACHINE PROTOTYPE

LinuxCNC was developed by NIST (National Institute of Standards and Technology) from USA [3,20]. LinuxCNC is a real-time control system with open architecture, which can be used control various kinds of machine tools and robots. Years of research went into development of LinuxCNC and it represents solid, time-proven machine control platform. Simplified structure of the control system, including mini CNC machine, is shown in Fig 7. LinuxCNC software system contains four base modules [3]: (i) movement controller EMCOT; (ii) discrete input/output signals controller EMCIO; (iii) process controller EMCTASK; (iv) GUI (Graphical User Interface).

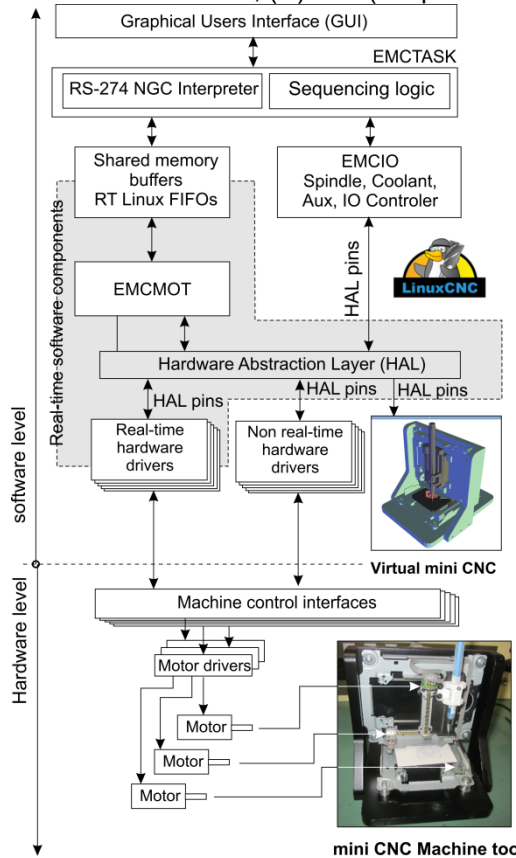

Fig. 7 ArchitectureLinuxCNC-afor mini CNC machine tool

EMCMOT module performs real-time interpolation of the programmed path according to the direct and indirect kinematic models and drives motors of all the axes accordingly. EMCIO module processes all peripheral operations and doesn't have direct connection with motor drivers.

EMCTASK module interprets G-code instructions and coordinates the activities of EMCOT and EMCIO modules accordingly. As seen in Fig.7, communication between real-time EMCOT module and non-real-time EMCTASK module is done through the shared memory buffer which is a part of RTLinux mechanism. GUI is an external module used for easier machine control, path visualization, code review etc. Different GUIs are available for LinuxCNC: TkLinuxCNC, MiniGUI, AxisGUI, GMOCCAPY GUI, while the one most commonly used is the Axis GUI. In our case, Axis GUI was used during demonstration of the mini CNC machine tool control system.

Significant contribution to expansion and popularization of LinuxCNC software was brought through the development of HAL (Hardware Abstraction Layer). HAL enables simple

integration of user-defined direct and inverse kinematic models into the control system. Also, it provides a uniform interface for hardware and software modules of the system, thus simplifying connection establishment.

In order to use LinuxCNC software to control the mini CNC machine, the following steps were necessary:

(I) Creating a directory which contains all the configuration files of the mini CNC machine tool;

- (II) Creating configuration (\*.ini) files which contain core machine parameters: range of all the axes, maximum velocity and accelerations of all the individual axes, parameters for real-time system operation etc;
- (III) Creating configuration (\*.hal) files which contain information relating to motion control of both real and virtual machine;
- (IV) Configuring the control system with regard to hardware platform being used as a host. Options here are regular personal computer, or compact (mini) computer, such as Raspberry Pi or Beagle Bone Black (Fig. 8).
- (V) Building and configuration of the interactive virtual mini CNC machine tool within the LinuxCNC system using the tools available in OpenGL-Python 3D environment.

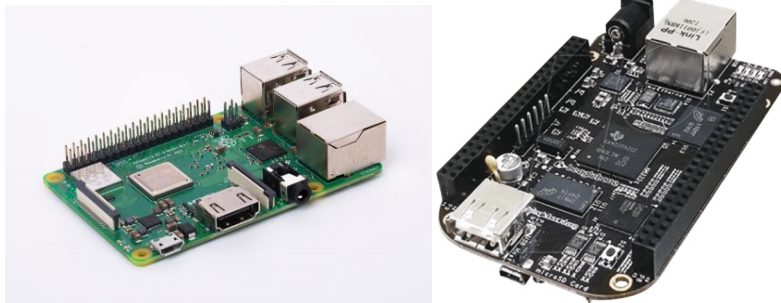

Fig. 8 *The compact PC platforms Raspberry Pi 3 Model B+ in BeagleBone black*

#### **4.1 CONFIGURING OF THE VIRTUAL MACHINE**

Configuring of the interactive virtual machine is done via Python programming language, which simplifies development of GUIs, GUI elements and allows primitive graphics modelling and integration of developed models directly into LinuxCNC control system [27,28]. Graphical model of the virtual machine is connected with the LinuxCNC core through OpenGL-Python hooks, which in turn allows correct movements of the virtual model. Afterwards, virtual model of the mini CNC machine can be used to simulate and verify machining programs directly in Axis GUI, or it can be used to monitor machine activity during machining operations, since the movements of the real and virtual machine are identical.

Details regarding the virtual machine in OpenGL-Python environment are given in the works [21-23]. In this paper, virtual machine used all models that were developed in PTC Creo. Models were converted from native Creo format into ASCII STL format (OBJ format works as well) and then loaded into Axis GUI through appropriate Python calls. Afterwards, imported components are properly oriented and placed in the virtual environment, resulting in fully functional virtual machine shown in Fig.9.

The virtual machine is placed in a separate window and allows toolpath drawing during movements of the virtual machine elements. During the execution of the machining program written in G code, virtual machine elements are moving in real-time, fully synchronized with moving elements of the real machine, with no visible latency.

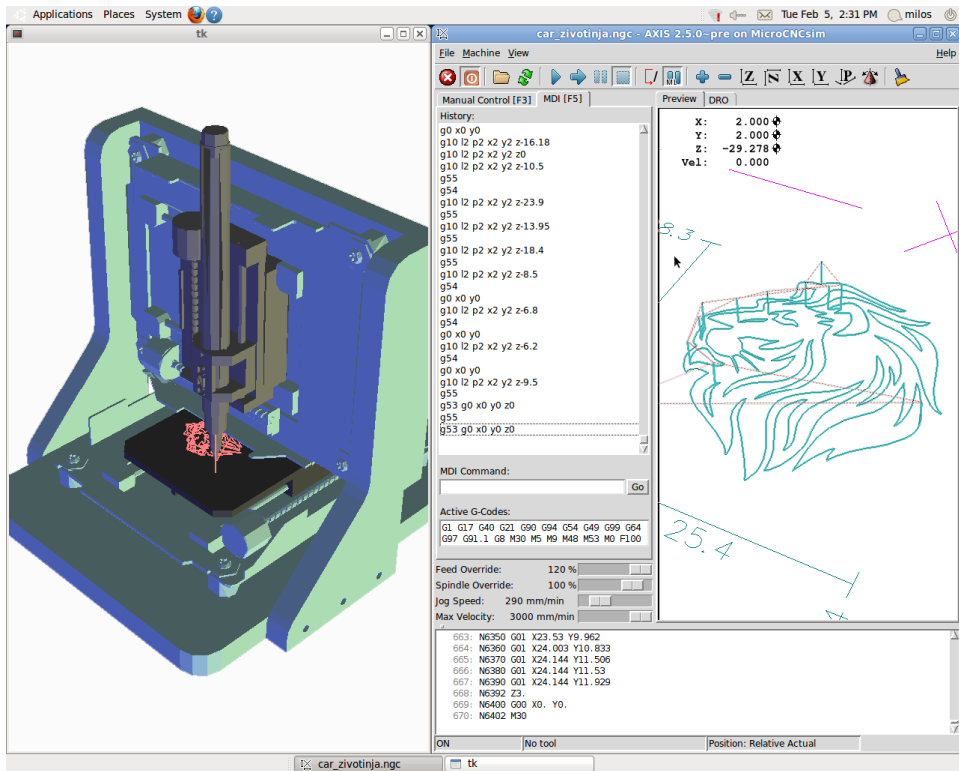

Fig. 9 The Virtual machine integrated with the graphic user interface AXIS

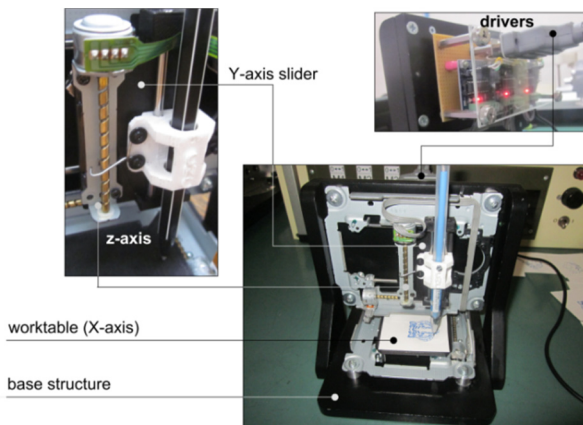

Fig. 10 Fully integrated mechanical and control hardware.

## 5. MACHINE TRIAL RUNS

After successful integration of the control system, trial machining was performed. Prototype of the mini CNC machine features compact design, with fully integrated hardware, shown in Fig.10. During trial runs, machine was supposed to draw several complex 2D contours within the available workspace. All the trials were completed successfully, with no detectable defects. Mini CNC machine

tool's work environment is shown in Fig.11a,b, while some of the programmed contours are shown in Fig.11c,d,e,f,g.

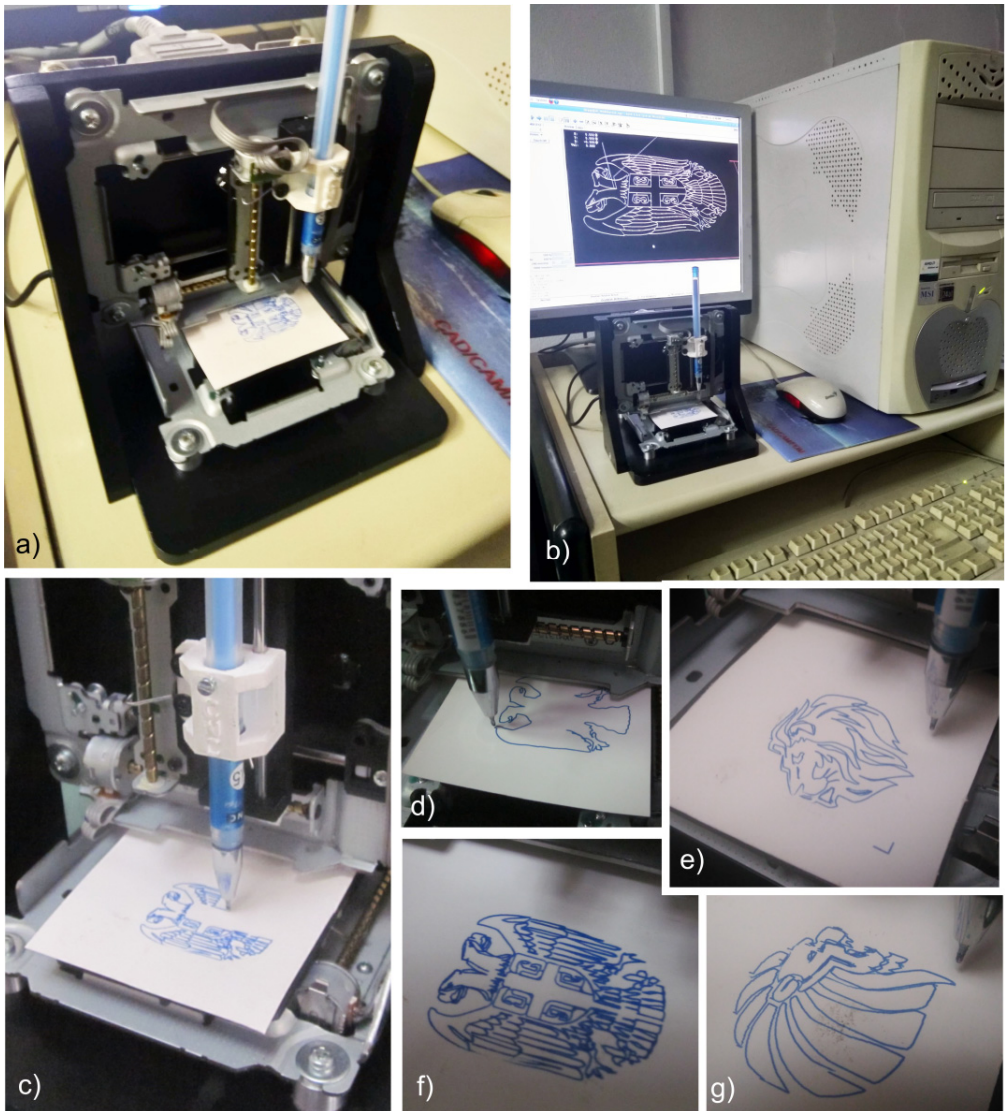

Fig. 11 *Machine work environment and results of several trials.*

LinuxCNC is suitable for integration of the virtual machine directly within the control system, as shown in section 4.1. Simultaneous operation of the real machine and the virtual machine has also been successfully tested and shown in Fig. 12.

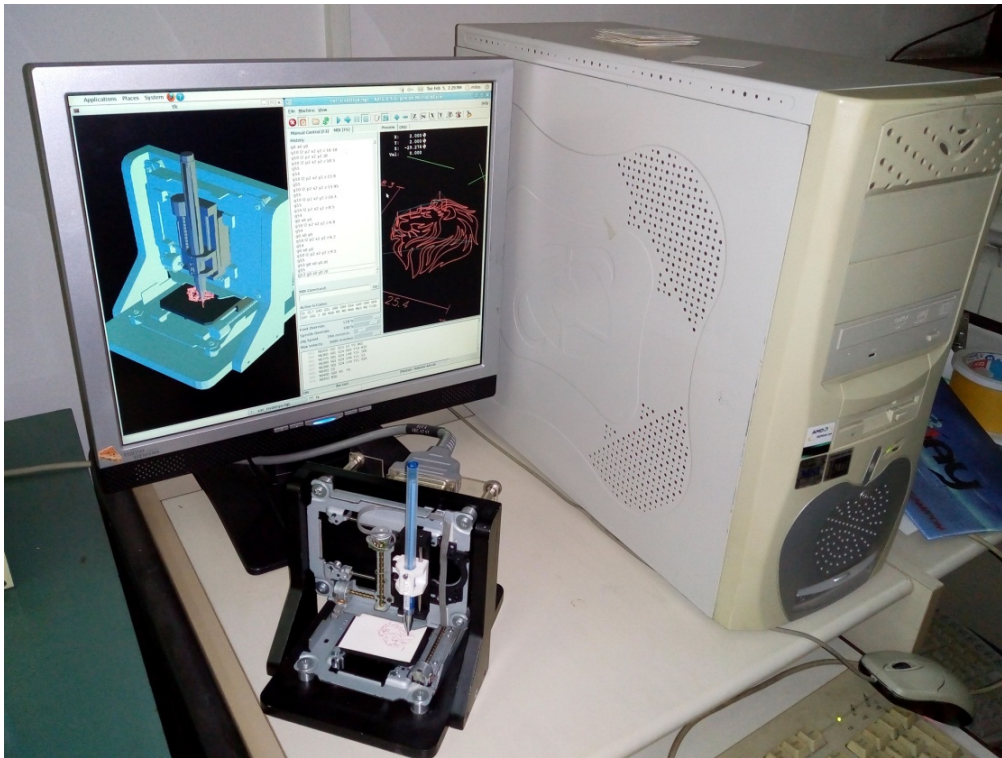

Fig. 12 Machine work environment with PC control system and integrated virtual machine in the background.

Test runs allow us to conclude the following: (i) no visible differences in the appearance of the drawn and programmed contours confirm that the realized concept is good, (ii) positioning accuracy within the boundaries of the machine workspace was good, (iii) the simultaneous work of virtual and real machine was successful.

## 6. CONCLUSION

3-axis mini CNC machine tool presented in this work was developed to create a suitable and economical environment for laboratory exercises and research in the field of micro and mezo machine tools. Presented machine can also be used for education and configuration of new machine tools, development of systems with open architecture control and CNC machine tool programming practice.

During the configuration of the mini CNC machine tool, following activities were realized: (i) adopting conception, designing and building of the machine tool, (ii) configuration of the machine tool control, (iii) simulation and verification of the virtual prototype, (iv) realization of the virtual prototype, (v) testing and trial runs of the machine tool.

Configuration of the new machine tools, revitalization of existing ones and self-construction of educational machine tools is one of the important factors for raising the

level of education quality. At the same time, educational processes rely heavily on software solutions, simulation and virtualization technologies. This can be an economically viable basis for improving the educational system in the field of production engineering.

Further activities include adaptation of the Z-axis of the mini CNC machine tool, so that it can carry a small laser, designated for laser engraving, as well as construction and development of other concepts regarding mini CNC machine tools.

## **ACKNOWLEDGEMENT**

This paper was made in the framework of research in project TR35022 and TR35023 which are proposed by the Ministry of Education, Science and Technological Development of the Government of the Republic of Serbia.

## **REFERENCES**

- [1] Živanović S., Glavonjić M., Milutinović D., Slavković N., Dimić Z., Kvirgić V. (2013). Educational system EDUMAT for Programming CNC machine. *National Conference with international participation RPPO13, Conference Proceedings (in Serbian)*, p. 298-305.
- [2] Živanović, S. (2012). *Development of educational parallel kinematic machine*, Monograph book (in Serbian). Zaduzbina Andrejevic, University of Belgrade Faculty of Mechanical Engineering, Belgrade.
- [3] Linux CNC, from <http://linuxcnc.org/>, accessed on 2019-01-16.
- [4] NEJE, from <https://www.gearbest.com/top-brands/brand/NEJE.html>, accessed on 2019-01-16.
- [5] 500MW DIY Laser Engraving Machine that carves 10 times Faster in Black Super Cool Design, from <https://eibuy.com/products/qdusa060030042>, accessed on 2019-01-23.
- [6] Mini laser CNC cut, from <https://grabcad.com/library/mini-laser-cnc-cut-1>, accessed on 2019-01-23.
- [7] How to make mini CNC 2D plotter using scrap DVD drive, L293D, from <https://www.hackster.io/user421848217/how-to-make-mini-cnc-2d-plotter-using-scrap-dvd-drive-l293d-420016>, accessed on 2019-01-16.
- [8] Build a mini CNC plotter out of old DVD drives, from <https://atmelcorporation.wordpress.com/2015/12/23/build-a-mini-cnc-plotter-out-of-old-dvd-drives/>, accessed on 2019-01-23.
- [9] EWaste 60\$ 3DPrinter, from, <https://www.instructables.com/id/eWaste-60-3DPrinter/>, accessed on 2019-01-23.
- [10] Cut 1mm Plastic With a 1 Watt Laser, from, <https://www.ponoko.com/blog/ponoko/cut-1mm-plastic-with-a-1-watt-laser/>, accessed on 2019-01-23.
- [11] Ada Gcode controller and e-waste CNC, from <https://hackaday.io/project/12031/gallery#22a84566ca4696063cd695d8b808abc5>, accessed on 2019-01-23.
- [12] Micro mini CNC Plotter-3D CAD Model Library, from <https://grabcad.com/library/micro-mini-cnc-plotter-1>, accessed on 2019-01-23.

- [13] Best Review Co, from <https://www.pinterest.com/pin/826340231601820214/>, accessed on 2019-01-23.
- [14] Arduino Mini CNC Plotter Machine From DvdDrives, from <https://www.instructables.com/id/Arduino-Mini-CNC-Plotter-Machine-from-dvd-drives/>, accessed on 2019-01-16.
- [15] DIY Arduino CNC Drawing Machine, from <https://www.instructables.com/id/DIY-Arduino-Drawing-Machine/>, accessed on 2019-01-16.
- [16] Kanife, P.O. (2016). *Computer Aided Virtual Manufacturing Using Creo Parametric*. Springer International Publishing Switzerland.
- [17] Zivanovic, S., Glavonjic, M., Milutinovic, D. (2015). Configuring A Mini-Laboratory and Desktop 3-Axis Parallel Kinematic Milling Machine, *Strojniški vestnik - Journal of Mechanical Engineering*, vol. 61, no.1, p. 33-42.
- [18] Zivanovic, S., Kokotovic, B. (2015). Configuring a virtual desktop 5-axis machine tool for machine simulation, *12th International Conference on Accomplishments in Electrical and Mechanical Engineering and Information Technology DEMI 2015 Conference Proceedings*, p. 255-262.
- [19] Real-Time Control Systems Library – Software and Documentation, from <https://www.nist.gov/el/intelligent-systems-division-73500/networked-control-systems-group/real-time-control-systems>, accessed on 2019-01-30.
- [20] Staroveški, T., Brezak, D., Udiljak, T. (2013). LINUXCNC – the Enhanced Machine Controller: application and an overview, *Tehnički vjesnik / Technical Gazette*, vol.20, no.6, p.1103-1110.
- [21] Dimić, Z., Živanović, S., Kvrđić, V. (2008). Configuring EMC2 for programming and simulation multi axis machine tools in Python virtual Environment. 32nd Conference on production engineering of Serbia with foreign participants, *Conference Proceedings (in Serbian)*, p. 353-356.
- [22] Dimic, Z., Milutinovic, D., Zivanovic, S., Kvrđić, V. (2016). Virtual environment in control and programming system for reconfigurable machining robot. *Tehnički vjesnik / Technical Gazette*, vol. 23, no. 6, p. 1821- 1829.
- [23] Živanović, S., Dimić, Z., Vasilčić, G., Kokotović, B. (2018). Configuring of a virtual reconfigurable 2-axis paralel kinematic machine integrated with the open arhitecture CNC system based on EMC2 software. *TECHNICS, Magazine of the Union of Engineers and Technicians of Serbia, Mechanical Engineering*, vol. LXXIII, no. 4., p. 519-526.