



www.sjm06.com

Serbian Journal of Management 17 (1) (2022) 5 - 14

Serbian
Journal
of
Management

INDUSTRY 4.0 IN SERBIA - STATE OF DEVELOPMENT

Vidosav D. Majstorović*, Radivoje Mitrović, and Žarko Mišković

*University of Belgrade, Faculty of Mechanical Engineering,
Kraljice Marije 16, 11000 Belgrade, Serbia*

(Received 24 February 2022; accepted 10 March 2022)

Abstract

A new model of automation of technological systems, based on the Internet, was defined as the concept of Industry 4.0, Germany in 2011. It represents an advanced model of connecting machines and computers (cyber-physical systems - CPS), their networking (cloud computing and Internet of Things (IoT)) with the widespread use of advanced artificial intelligence (AI) in this concept. This concept is a model of smart manufacturing (SM), and today we are talking about: smart vehicles, smart highways, smart grids, smart cities, smart services, etc ... – in short, intelligent "everything and anything" (smart everything). The most important directions for Serbia in the application of Industry 4.0 include: industrial policy for Industry 4.0, education for Industry 4.0 (higher / secondary education), research for Industry 4.0, and especially applied research and readiness of SMEs for Industry 4.0, as well as the application of this model in practice. This paper presents the development and application of the Industry 4.0 model in Serbia, through the activities of the Faculty of Mechanical Engineering in Belgrade, from 2015 until today, with special reference to the application of Industry 4.0 in mining.

Keywords: Industry 4.0, Application, Serbia

1. INTRODUCTION

Today's generation is witnessing the digitalization of all production processes and activities, and this inevitable, fundamental change in the industry has been marked as the fourth industrial revolution or Industry 4.0.

The existing methodologies and ways of creating value are not enough to meet the growing demands for lower product prices, stability of delivery, efficiency and constant changes in production itself. Industry 4.0, defined as "smart manufacturing" (SM), supported by the "Industrial Internet of Things" (IIoT), is affecting entire production

* *Corresponding author: vidosav.majstorovic@gmail.com*

DOI: 10.5937/sjm17-36626

systems and chains in different industries, performing a global transformation in design, planning, production and delivery goods and services. Rapid advances in digitization and the technologies that support it, such as Internet of Things and Services (IoT / IoS), Cyber Physical Systems (CPS), Big Data Analytics (BDA), and Cloud Computing (CC) have taken on significant role.

H. Rauen, Deputy Executive Director of the German Mechanical Industry Association (VDMA), said in 2012 (Recommendations for ..., 2013): "Implementation starts with small steps, here and there, there will be no big bang that will introduce Industry 4.0 immediately. On the contrary, it will come step by step. But when we look back in ten years, we will see that the world has changed significantly".

Today, after a decade of introduction Industry 4.0, we can define common elements for the Industry 4.0 economy (2030 Vision, 2019):

(i) smart design and planning of products and technologies. With the rapid development of new technologies such as VR (virtual reality) and augmented reality (AR), traditional design will be upgraded and will enter a "smart era". Design software, such as computer-aided design (CAD) for all areas, and computer-aided manufacturing (CAM), is able to communicate with physical smart prototype systems in real time, enabling three-dimensional (3D) printing integrated with CPS and AR.

(ii) smart machines. In Industry 4.0, smart machines can also be realized with the help of smart robots and various other types of smart objects, which are able to monitor events in the environment in real time and

communicate with each other. For example, smart machine tools, such as CPS, can collect real-time data and send them to a central system in the cloud, so that machine tools and their digital twins can synchronize their services to provide smart manufacturing solutions.

(iii) smart tracking. Online monitoring is an important aspect for the operation, maintenance and optimal scheduling in Industry 4.0 for manufacturing systems. Widespread use of different types of sensors enables smart tracking. For example, data and information on various production factors such as temperature, power consumption, vibration and cutting speed can be obtained in real time.

(iv) smart management. In Industry 4.0, flexible high-variability production management (i.e., smart management) is achieved through the development of cyber-physical production management systems. Smart management is mainly performed through the physical management of various smart machines or devices through a platform supported by the cloud. End users can monitor and / or turn off the machine or robot via their smartphones.

(v) smart scheduling. The level of smart scheduling mainly includes advanced models and algorithms for displaying collected data using sensors. Data-based techniques and advanced decision-making architecture can be used for smart scheduling. For example, to achieve reliable real-time scheduling and execution, distributed smart models use a hierarchical interactive architecture.

All these elements form the framework for the application of Industry 4.0 in manufacturing and other industries.

2. INDUSTRY 4.0 IN SERBIA - ACTIVITIES OF THE FACULTY OF MECHANICAL ENGINEERING

It has been stated above that the Industry 4.0 Programme started in Germany in 2011. It was a signal for the majority of advanced manufacturing countries in the world to follow the same path. It should be emphasised that until then, no technology initiative such as this one had immediately found understanding and support around the world as was the case with the Industry 4.0. This is explained by the fact that Germany, undoubtedly both then and now, a world industrial leader, has defined and accepted Industry 4.0 as a strategic programme of technological development, making it clear to the whole world what the undoubted future is in this area. Today, at the end of the second decade of the 21 century, Industry 4.0 has become a global scientific and technological programme for the development of all industries, especially in industrialized countries.

Since 2015, the Faculty of Mechanical Engineering in Belgrade has taken over a large number of activities related to Industry 4.0 and its application in our country, *through the paradigm: Digitization of production driven by the knowledge economy*. In that sense, the following activities have been undertaken (until November 2021):

1. Five International Conferences were held - US-EU-Far East –Serbia, Technology Summit Industry 4.0 and the new industrialization of Serbia 2016-2020. Due to the covid 19 pandemic, this Conference has been suspended, and will be resumed when epidemic conditions permit. Invited 138 world experts (126 from abroad), spoke about the latest developments and research in

the field of manufacturing technologies in the context of Industry 4.0. The focus of the Conference was the following: the first (2016) - Industry 4.0 as a framework for the new industrial policy of Serbia; the second (2017) - Intelligent products; the third (2018) - Big Data Analysis (BDA); the fourth (2019) - Industry 4.0 for small and medium organizations; and the fifth (2020) - Industry 4.0 and manufacturing in the cloud. Since 2018, the Proceedings of this Conference have been published by Springer, the world's most famous publisher of technical literature, which gives it exceptional weight. These Proceedings can be found at the following links:

a. Proceedings of 3rd International Conference on the Industry 4.0 Model for Advanced Manufacturing - AMP 2018, June 5-7. Editors: Ni, Jun, Majstorovic, Vidosav D., Djurdjanovic, Dragan (Eds.). <https://www.springer.com/gp/book/9783319895628>.

b. Proceedings of the 4th International Conference on the Industry 4.0 Model for Advanced Manufacturing - AMP 2019, 3-6 June. Editors: Monostori, L., Majstorovic, V.D., Hu, S.J., Djurdjanovic, D. (Eds.). <https://www.springer.com/gp/book/9783030181796>.

c. Proceedings of 5th International Conference on the Industry 4.0 Model for Advanced Manufacturing - AMP 2020, 1 – 4 June. Editors: Wang, L., Majstorovic, V.D., Mourtzis, D., Carpanzano, E., Moroni, G., Galantucci, L.M. (Eds.). <https://www.springer.com/gp/book/9783030462116>.

On the other hand, one of the presidents and founders of this Conference is Prof. Dr. Yun Ni, Advisor to President Obama and Xi Jinping on Technological Development, Co-Chair of the Industry 4.0 Industry Panel of

the World Economic Forum (WEF) in Davos, Switzerland.

2. The 35th Panel (3 International, with Slovakia, Germany and USA, until October 2021), on Industry 4.0 was organised throughout Serbia and Republic of Srpska with the aim of connecting economies - government / SCC - university / institutes, and creating a national movement to implement these models in the industry today and tomorrow in our society. <https://vesti.mas.bg.ac.rs/?p=10385>.

3. A framework for research in this area was opened. Fifteen papers were published (until December 2021) with the results of the research of our research team for the Industry 4.0 / CP3M model, at the most famous CIRP Conferences - <https://www.cirp.net/>, in this area.

4. Master studies for Industry 4.0 were established at the Faculty of Mechanical Engineering in Belgrade.

5. Several courses in this area were introduced into the doctoral study program - <https://www.mas.bg.ac.rs/studije/ds/start>.

In this way, the Faculty of Mechanical Engineering in Belgrade became the regional leader of the movement for Industry 4.0 in the field of research, development and application in the mechanical engineering industry.

The digital Platform Industry 4.0 of Serbia (Majstorovic et al., 2016, 2019) is a unique vision of the strategy of connecting all stakeholders, especially industrial sectors using ICT for their digital transformation, with the aim of raising the competitiveness of Serbian industry in the global market. It connects industry, educational and research institutions, decision makers and NGOs, on common goals of digital industry transformation.

The platform is part of the Industrial Policy of Serbia 2020/2030, and it helps our country to be in the group of 45 countries in the world that systematically develop and implement the concept of Industry 4.0, the basic framework of the fourth industrial revolution. The platform is the National Strategic Initiative of the Faculty of Mechanical Engineering in Belgrade as a representative of the Alliance Industry 4.0 Serbia, the Ministry of Economy and the Serbian Chamber of Commerce. The political levers of the Platform include the initial design phase, the visionary and top-down management role of the Ministry of Economy and the Serbian Chamber of Commerce in the form of developing a strategy for the application of this concept in practice. The expected results include: acceleration of innovation and implementation of industrial solutions for Industry 4.0 in practice, a new generation of trained and highly qualified professionals (engineers and operators 4.0) and the development of a sustainable and competitive industrial system in Serbia.

The main goals of the Platform are:

(1) to increase the share of industry in the GDP of Serbia from the current 13% to 30% by 2030;

(2) to increase R&D investment from the current 0.6% to 1% of GDP by 2025;

(3) to increase the innovation potential and exports of domestic enterprises;

(4) to reduce of standardized and low-paid work and activities in industry, with an increase in the volume of value-added products;

(5) to increase highly intellectual activities and application of ICT technologies in industry.

Industry 4.0 platforms have the following units:

1. Education and training
2. Production in value chains - business models of organizations, especially for SMEs
3. IC Technologies and their models for Industry 4.0
4. Industry 4.0 Cyber-Physical Pilot System / Center of Excellence for Mechanical Engineering
5. Innovation and business models for Industry 4.0

The platform represents a common strategic vision of the new industrialization of Serbia. The main role of the Platform is to generate recommendations and facts for the Policy of the Government of the Republic of Serbia in the field of economic and industrial development for the period 2020/2030.

3. SOME RESEARCH RESULTS

As mentioned, Faculty of Mechanical Engineering has launched several studies in the field of Industry 4.0, and here is an example from mining.

When we start from the structure of the

Industry 4.0 model, we use it to transform manufacturing into digital manufacturing. This means that the key elements of this production model are: machines and devices such as cyber-physical systems (CSP), Internet of Things (IoT), cloud computing (CC), big data analysis (BDA), artificial intelligence (AI) and machine learning (ML). At the workshop level, the most important element is the ERP model for resource planning. All this enables additional functions of digital manufacturing: monitoring and diagnostics of the system, environmental sustainability, saving resources and monitoring the efficiency of the system (Oztemel & Gursev, 2020).

Starting from today's level of computer model for planning and managing the operation of auxiliary machinery at the open pit mine "Drmno" (Majstorovic et al., 2016, 2021), the research model according to the concept of Industry 4.0 for this case is shown in Figure 1 (Karre et al., 2017). It includes two approaches: (i) development and implementation of maintenance models for heavy machinery, such as cyber physical systems, and (ii) planning and management

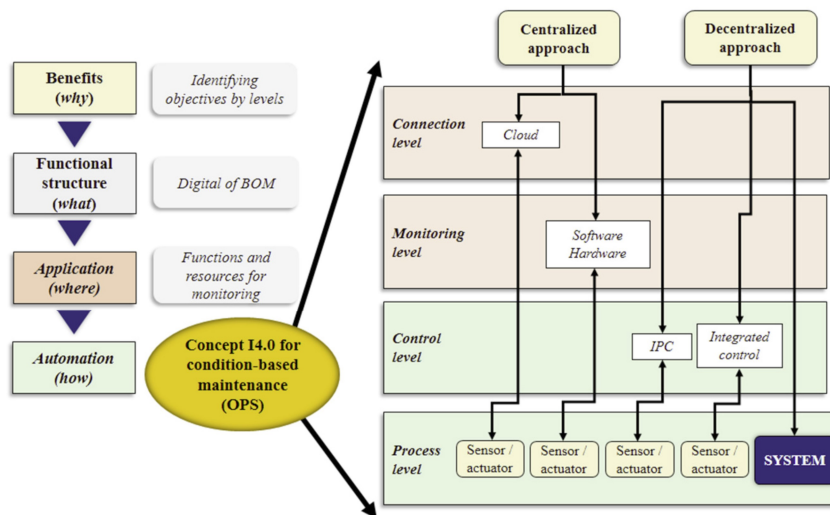

Figure 1. Industry Model 4.0 for condition based maintenance (adapted according to (Karre et al., 2017))

of maintenance resources using the ERP model for Industry 4.0.

Thus, for example, Figure 1 shows the case of condition based maintenance, as the most vital module of this concept, which has been designed for heavy mechanization at the open pit mine "Drmno". It has been set and developed on the model of engineering problem solving in this area, giving answers / solutions to the following questions: why (parameters of normal operation) - what (deviation from the prescribed value) - where (machine structure) - how (maintenance technology)! The answer to this last question is the application of the Industry 4.0 model, which is shown in this figure, through four levels. The essence is at the last level - processes, elements of machine systems of auxiliary mechanization in operation are monitored online, which creates an automated system for planning and monitoring its operation. The scientific

contribution of this approach is that the general Industry 4.0 model based on the integration and connection of cyber physical systems, the Internet of Things and cloud computing, analysis and synthesis methods, has been designed and applied to improve processes in a new way and on a new basis. These are based on the application of computer information systems, which usually work off-line, and with the assistance of engineers / maintenance planners.

A cyber physical model for open pit mechanization operation management is shown in Figure 2.

It has two levels: the physical (includes machine and computer systems for executing and managing processes at this open pit mine) and virtual part, which includes software systems and applied models for planning and managing processes that perform the physical element of the model. The whole system includes four modules:

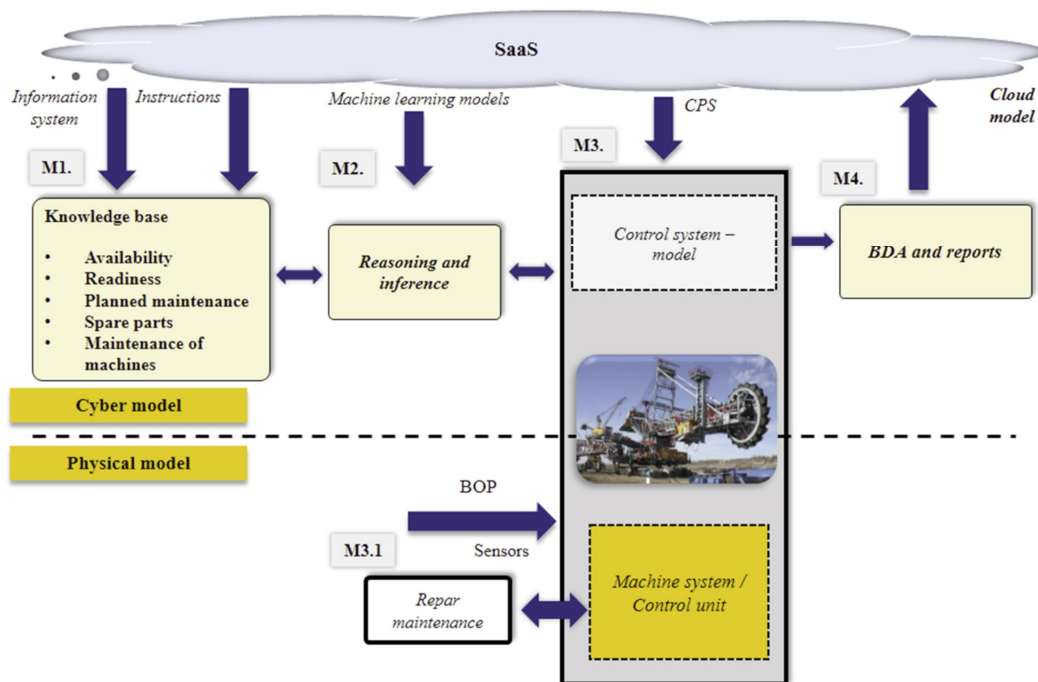

Figure 2. Cyber physical model for managing the exploitation of auxiliary machinery at the open pit mine (design solution)

M1 - knowledge base for operation and maintenance, M2 - intelligent analysis and synthesis based on the use of schell intelligent agent for these purposes, M3 - machine system of auxiliary machinery with its h / s structure (M3.1), and M4 - agent of large data set analysis and reporting.

The Industry 4.0 model for condition based maintenance, developed for heavy machinery at the open pit mine, is shown in Figure 3 (Majstorovic et al., 2021; Li et al., 2017), and it has five modules.

Module **a**, like IoT using wireless technology, collects data through various sensors, from the machine assemblies of the cyber physical system - excavators, noise and vibration signals that characterize the state levels of the monitored machine elements. Module **b** represents a subsystem of synthesis and analysis of large data sets

through four steps (cleaning, integration, feature extraction and transformation - reporting). Module **c** is an intelligent agent for diagnosing and forecasting the state of machine elements. Module **d** is an agent for monitoring CPS maintenance parameters via KPIs, such as: availability, reliability and others. Finally, the module **e** is the CPS itself when the whole system is developed.

Model Industry 4.0 is a hardware / software structure for real-time integration and process management. For our research, the same approach applies, so the h / s structure of the designed Industry 4.0 model for the management of operation and reflection of auxiliary machinery is shown in Figure 4.

Total architecture includes: hardware, components (physical / virtual), software

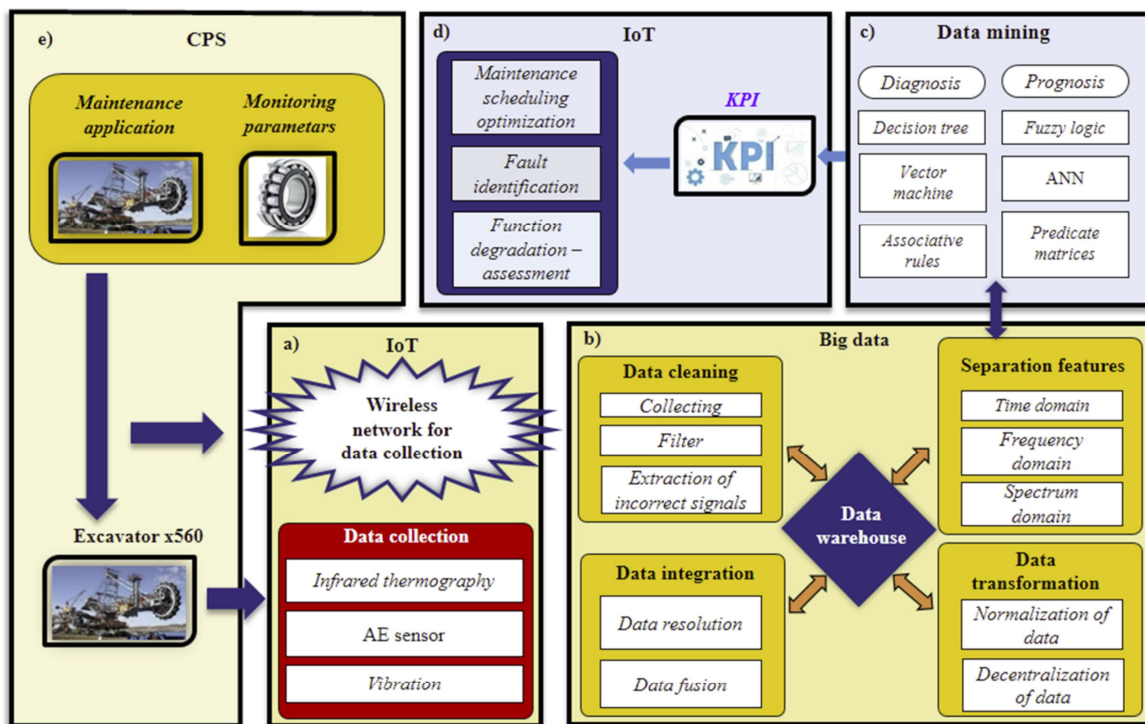

Figure 3. Structure of the condition based maintenance model according to the state of auxiliary mechanization according to the concept of Industry 4.0 (adapted according to (Majstorovic et al., 2021; Li et al., 2017))

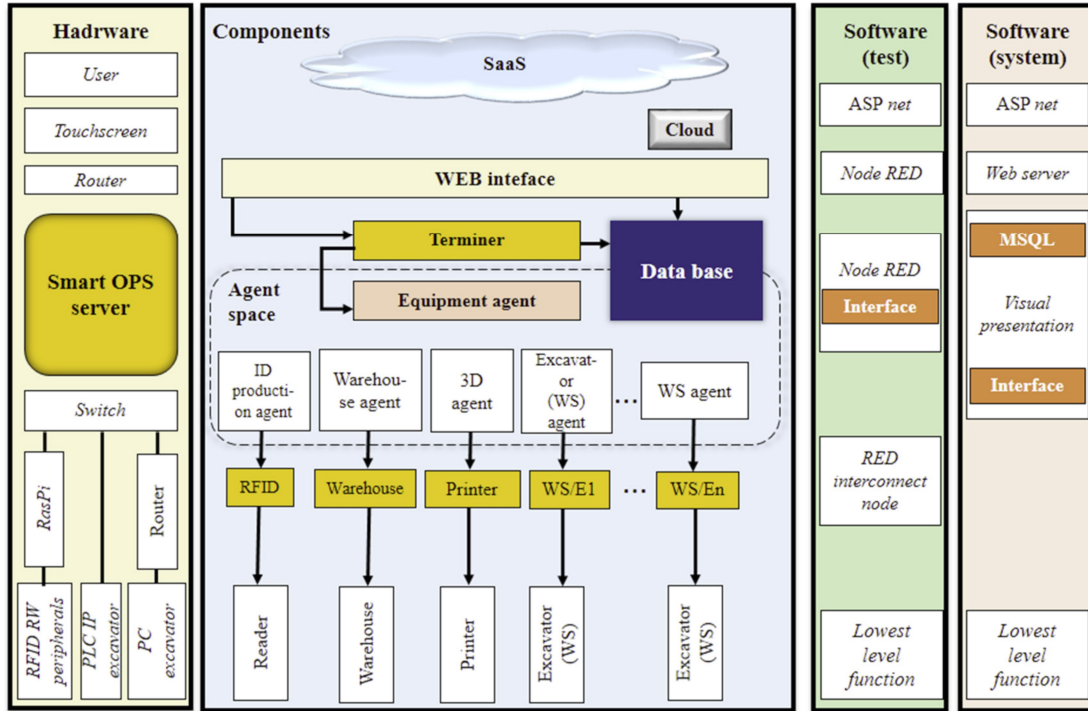

Figure 4. Architecture of the model for maintenance management of auxiliary machinery (MAM) on PK "Drmno" (project solution)

(test, system), by vertical structure.

As show in the picture, the excavator as

The cyber physical model of the excavator from the aspect of the application of the Industry 4.0 model has the structure as show in Figure 5.

the CPS has all the elements as our model in the Figure 3.

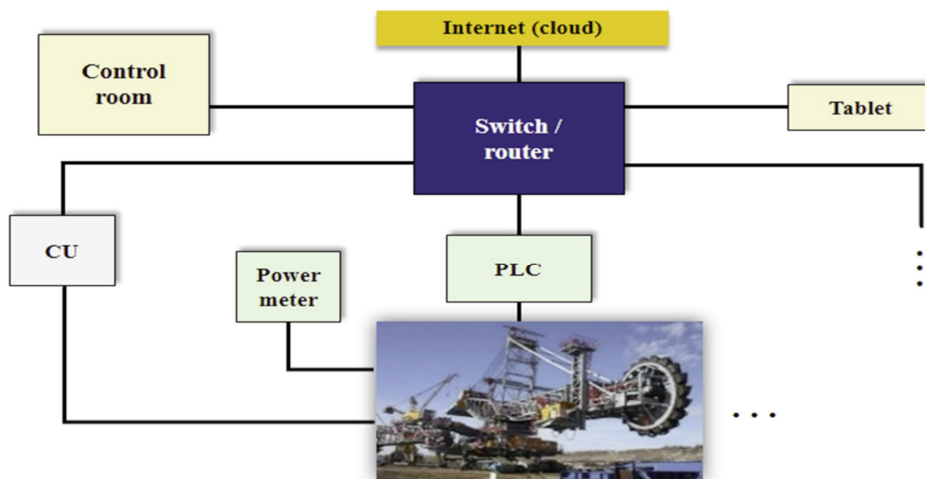

Figure 5. Block model of cyber physical control system on the example of a bulldozer on open pit mine "Drmno" (project solution)

4. CONCLUSION AND FUTURE RESEARCH

In our model, planning and management of open pit mining maintenance operations is performed using the ERP model. It represents an upgrade of the existing information system applied at this open pit mine. Open pit data, such as: production data, operation data, maintenance data are generated through: work orders, downtime charts, maintenance plans, spare parts inventory overview, maintenance tool plans, etc. All of this is made as a model of the digital twin, which connects to the real open pit mine through agent technology: identification, authorization, configuration, capacity, status and metadata are defined for each agent. The cloud data warehouse (SaaS model) is an information center that stores and exchanges all production data from the open pit mine. The Data Analysis Centre creates, stores, retrieves and investigates model uncertainty, using machine learning models, statistical or stochastic concepts, based on mathematical functions needed to create data-driven models, provided by the ERP model data. Each agent takes over such models through intermediaries and decides on predictive operations and controls, based on the results given by the models for open pit mine.

Applications for production at this mine may include, as appropriate, those such as CAD (3D models of systems and their components), CAQ (QMS) and ERP (surface mining and maintenance planning and maintenance of machine systems) systems. The platform uses an interface to communicate. All activities at the open pit mine are monitored and managed. The following are used for this: agent manager, data manager, job manager and security

controller. In this whole concept are the most important knowledge, which is generated in the production processes at the open pit mine.

References

2030 Vision for Industrie 4.0 – Shaping digital ecosystems globally, Federal Ministry for Economic Affairs and Energy (BMWi), Berlin, 2019. www.bmwi.de. Accessed February 2022.

Karre, H., Hammer, M., Kleindienst, M., & Ramsauer, C. (2017). Transition towards an Industry 4.0 state of the LeanLab at Graz University. *Procedia Manufacturing*, 9, 206-213.

Li, Z., Wang, Y., & Wang, K. (2017). Intelligent predictive maintenance for fault diagnosis and prognosis in machine center: Industry 4.0 scenario. *Advances in Manufacturing*, 5 (4) 377-387.

Majstorovic, V., Mitrovic, R. & Miletic, M. (2016). Program - Advanced Industrialization of Serbia and Industry Policy. Horizon 2020/2030. Mechanical Engineering Faculty. www.mas.bg.ac.rs. Accessed February 2022.

Majstorovic, V., Mitrovic, R. & Miletic, M. (2019). Industry 4.0 – National Program of Serbia. Mechanical Engineering Faculty, Belgrade. www.mas.bg.ac.rs. Accessed February 2022.

Majstorovic, V., Mitrovic, R. & Miskovic, Z. (2019). Industry 4.0 Programs Worldwide. Proceedings of the 4th International Conference on the Industry 4.0 Model for Advanced Manufacturing, AMP 2019, Belgrade. pp. 79-99.

Majstorovic, V., Simeunovic, V., Miskovic, Z., Mitrovic, R., Stosic, D., & Dimitrijevic, S. (2021). Smart

ИНДУСТРИЈА 4.0 У СРБИЈИ – СТАЊЕ РАЗВОЈА

Видосав Д. Мајсторовић, Радивоје Митровић и Жарко Мишковић

Извод

Нови модел аутоматизације технолошких система, заснован на Интернету, дефинисан је као концепт индустрије 4.0, Немачка 2011. године. Представља напредни модел повезивања машина и рачунара (енг. cyber-physical systems - CPS), њиховог умрежавања (енг. cloud computing and Internet of Things (IoT)) са широко распрострањеном употребом напредне вештачке интелигенције (енг. artificial intelligence (AI)) у овом концепту. Овај концепт је модел паметне производње (енг. smart manufacturing (SM)), а данас говоримо о: паметним возилима, паметним аутопутевима, паметним мрежама, паметним градовима, паметним услугама итд... – укратко, интелигентно „све и свашта“ (паметно све). Најважнији правци за Србију у примени индустрије 4.0 су: индустријска политика за индустрију 4.0, образовање за индустрију 4.0 (високо/средње образовање), истраживање за индустрију 4.0, а посебно примењена истраживања и спремност МСП за индустрију 4.0, као и примена овог модела у пракси. Овај рад представља развој и примену модела индустрије 4.0 у Србији, кроз делатност Машинског факултета у Београду, од 2015. године до данас, са посебним освртом на примену индустрије 4.0 у рударству.

Кључне речи: Индустрија 4.0, примена, Србија

Manufacturing as a framework for Smart Mining, 54th CIRP Conference on Manufacturing Systems, Procedia CIRP, 104, 188–193.

Oztemel, E., & Gursev, S. (2020). Literature review of Industry 4.0 and related technologies. Journal of Intelligent Manufacturing, 31 (1), 127-182.

Recommendations for implementing the strategic initiative INDUSTRIE 4.0, Securing the future of German manufacturing industry Final report of the Industrie 4.0 Working Group, April 2013. <https://www.din.de/blob/recommendations-for-implementing-industry-4-0-data.pdf>. Accessed February 2022.