



ECF22 - Loading and Environmental effects on Structural Integrity

## Design and testing characteristics of thin stainless steel diaphragms

B. Perić<sup>a,\*</sup>, A. Simonović<sup>a</sup>, T. Ivanov<sup>a</sup>, S. Stupar<sup>a</sup>, M. Vorkapić<sup>b</sup>, O. Peković<sup>a</sup>, J. Svorcan<sup>a</sup>

<sup>a</sup>University of Belgrade, Faculty of Mechanical Engineering, Kraljice Marije 16, 11120 Belgrade, Serbia

<sup>b</sup>University of Belgrade, ICTM - CMT, Njegoševa 12, 11000 Belgrade, Serbia

### Abstract

Metal membranes are defined as thin steel circular plates. The metal membranes are widely used in the measurement technique and they are constantly loaded over the entire surface. In case that a membrane is loaded with uniform load over the entire surface. In case that the membrane is stiffened over the edge, then it is called a diaphragm. According to the making method membranes are divided into flat and corrugated. Corrugated membranes are used mainly in a low pressure area. Membranes are most commonly made of firm alloy austenitic steel. In this paper numerical and experimental analysis of a thin corrugated diaphragm 24 mm diameter is presented, with variable material thickness and variable corrugations geometry. Experimental tests are conducted on a corrugated stainless steel (AISI 316) diaphragm. Experimental results are compared with numerical results in ANSYS software package. A comparative analysis of the sinusoidal and toroidal diaphragms has shown that there is a higher sensitivity of the sinusoidal diaphragm, that is, if the thickness of the diaphragm increases, and their stiffness is increased. In general, for small pressure ranges from 10 mbar to 50 mbar, the sinusoidal diaphragms have a faster response.

© 2018 The Authors. Published by Elsevier B.V.

Peer-review under responsibility of the ECF22 organizers.

*Keywords:* diaphragm, deflection, corrugation, geometrical parameters

### 1. Introduction

When exposed to pressure ( $p$ ) metal membranes as thin circular plates experience elastic deformation ( $w$ ) or axial load (Gawade and Chavan, 2013). They represent the most important mechanical part for measuring instruments, because its characteristics influence the quality and accuracy of measurement. Membranes are widely used in

\* Corresponding author. Tel.: +381 (11)3302242;

E-mail address: [bperic@mas.bg.ac.rs](mailto:bperic@mas.bg.ac.rs)

measuring elements of high accuracy classes. Using membranes, a pressure of hundreds of atmospheres up to several millimeters of water column can be measured. Also, a membrane is used as a partition wall between the two environments or as a flexible sealant for registering movements from the pressure or vacuum area. When the membrane is clamped (locked, welded) along the edge, it is then called a diaphragm (Giovanni, 1982). A diaphragm receives pressure from one side, which leads to its deformation. After cessation of pressure, the diaphragm returns to its original position.

Corrugated membranes are obtained by pressing thin metal foils in special tools. Membranes are most often made of high alloy austenitic steels (Giovanni, 1982). These materials are characterized by high corrosion resistance, good spring properties and stable operation at high temperatures from 250°C to 400°C. Stainless steels AISI 300 have a great application in making membranes. This series is characterized by fatigue resistance, high density and modulus of elasticity, high thermal expansion coefficients and the smallest thermal conductivity.

By structure, membranes can be straight or corrugated. Straight membranes show a non-linear relationship between the deflection and the applied pressure. For relatively small deflections, this ratio is approximately linear, while non-linearity is created due to larger deflections (Spiering et al. 1993; Scheeper et al. 1994).

For small deflections, a corrugated membrane is less deflected compared to a flat membrane of the same surface and thickness. With a corrugated membrane, it is possible to control mechanical sensitivity by changing geometry parameters (Giovanni, 1982; Scheeper et al., 1994): 1)  $H$  - depth of corrugations; 2)  $h$  - thickness of diaphragm/membrane and 3)  $n$  - number of corrugations. The elements of a corrugated membrane are: 1) a solid center which represents a flat part of the membrane; 2) the different corrugation profiles; and 3) the extreme waves of the membrane (Scheeper et al. 1994).

The existence of an ultimate wave is necessary because of stiffening membrane - diaphragm. The final wave can be in the form of a cylinder or plane. Circular corrugations on profiles can be toroidal or sinusoidal. The thin corrugated membrane with small toroidal corrugations is quite sensitive and is used to measure small pressures.

Corrugated membranes are very sensitive to such tightening, in particular membranes with low stiffness (Giovanni, 1982). If the membrane is taut at the initial level, it causes its rigidity to fall, while the spring feature can become rising. Conversely, when tightening the membrane, stiffness increases.

When fixing the membrane, the construction and accuracy of the clamping surfaces is of great importance, as well as the correct surface treatment of the contact surface and the fixing ring. In Fig. 1, a membrane fixing assembly is shown. The contact surface of the membrane and the fixing ring should be parallel to each other, in order to eliminate the appearance of deformations that significantly affect the spring characteristics of the membrane. The steel sheet for the formation of the membrane must be made with the exact diameter according to the defined tool.

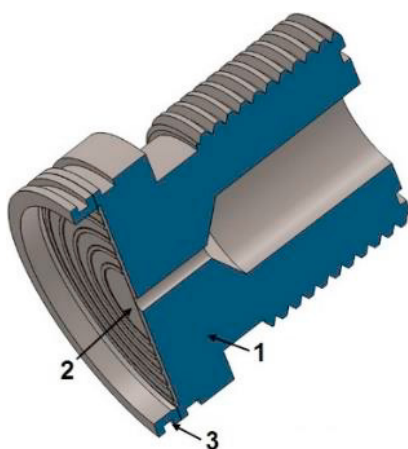

Fig. 1. Appearance of the assembly for stiffening the membrane: 1 - housing; 2 – diaphragm; 3 – fixing ring

## 2. Circular corrugated diaphragm calculation

In Table 1, important parameters are given for the design of a corrugated diaphragm.

Table 1. Characteristic parameters for corrugated diaphragm

Symbol	Description	Unit
p	Applied pressure	[N/mm <sup>2</sup> ]
q	Corrugation profile factor	-
w <sub>0</sub>	Deflection	[mm]
E <sub>d</sub>	Young's modulus of elasticity of material	[N/mm <sup>2</sup> ]
ν	Poisson's ration of the material of the diaphragm	-
H	Depth of the corrugation	[mm]
h <sub>d</sub>	Thicknes of diaphragm	[mm]
R <sub>d</sub>	Radius of diaphragm in	[mm]
S	Corrugation arc length	[mm]
l	Corrugation spatial period	[mm]
S/l	Corelation factor	-
y	Central deflection	[mm]

The elastic characteristic of the corrugated membrane is given by the equation Eq. (1):

$$w_0 = f(p); p = A \cdot w_0 + B \cdot w_0^3 \quad (1)$$

First article (A), in equation Eq. (1) determines the resistance equivalent to the membrane deflection and can be determined based on a linear solution. The second member (B), or cubic member, in the equation Eq. (1) is characterized by the stretch resistance of the membrane, where it is necessary to consider the deformation of the membrane. This article can be improved by stiffening the edges around the periphery (Spiering at al. 1993). By changing the value of the coefficients A and B in the equation Eq. (1) the equation Eq. (2)

$$A = \frac{E_d}{R_d^4} \cdot h_d^3 \cdot a_d; B = \frac{E_d}{R_d^4} \cdot h_d \cdot b_d; p = a_p \cdot E_d \cdot \frac{h_d^4}{R_d^4} \cdot \frac{w_0}{h_d} + b_p \cdot \frac{E_d}{1-\nu^2} \cdot \frac{h_d^4}{R_d^4} \cdot \frac{w_0^3}{h_d^3} \quad (2)$$

Values of coefficients  $a_d$  and  $b_d$  from equation Eq. (2) are calculated according to the following equation Eq. (3) (Kressmann et al., 2002; van Millem, 1991):

$$a_d = \frac{2 \cdot (q+1) \cdot (q+3)}{3 \cdot (1-\frac{\nu^2}{q^2})}; b_d = 32 \cdot \frac{1-\nu^2}{q^2-9} \cdot \left[ \frac{1}{6} - \frac{3-\nu}{(q-\nu) \cdot (q+3)} \right] \quad (3)$$

The consequences of the diaphragm compaction are determined by the correction factor of the shape of the profile (q) (Spiering at al. 1993;). The functional link for coefficients  $a_d$  and  $b_d$  over coefficients  $k_1$  and  $k_2$  is given by the following relationship from the equation Eq. (Dissanayake et al., 2009):

$$q^2 = k_1 \cdot k_2; k_1 = \frac{S}{l}; k_2 = 1 + 1,5 \frac{H^2}{h_d^2} \rightarrow q^2 = \left(\frac{S}{l}\right) \cdot \left(1 + 1,5 \frac{H^2}{h_d^2}\right) \quad (4)$$

The coefficients  $k_1$  and  $k_2$  depend only on the geometry of the profiled membrane and its thickness, while the coefficient  $k_1 \leq 1$ . The coefficient  $k_2$  is equal to the ratio of the moment of inertia and axial cross-section of the profiled membrane and can be  $k_2 \gg 1$ .

According to Jerman (1990), the coefficient  $q$  varies from 1 for straight diaphragms to a value approaching 1.22 times to the ratio of the wave and the thickness of the diaphragm. For conventional profiled metal diaphragms, the value of  $q$  is chosen to be between 10 and 30. It is clear that the coefficient  $a_d$  rapidly increases with increasing  $q$ , while the coefficient  $b_d$  rapidly decreases with increasing  $q$ , which can be represented by the equation Eq. (5):

$$\frac{a_d}{b_d^3} = \frac{A}{B^3} \left( \frac{E_d}{R_d^4} \right)^2 = f \left( \frac{H}{h_d} \right) \tag{5}$$

The ratio of the  $H/h_d$  profile is one of the basic geometrical parameters of the membrane by which its properties are determined. With the increase in the depth of the waves, the membrane becomes round, and the spring feature is linear. Increasing the wave depth causes a reduction in the deflection, but only at the initial part of the characteristic. With larger deflections, the impact of the wave depth is reversed.

### 3. Finite element analysis

This paper examined the AISI 316 steel sheet diaphragm. A wound diaphragm of diameter Ø24mm was used, with a constant corrugation number and profile thicknesses, but with a variable range of folds. In Table 2, the input parameters are related to the diaphragm.

Table 2. Input parameters for diaphragm

Symbol	Description	Value
$Dd$	Diameter (full)	24 [mm]
$Rd$	Radius (working area)	11 [mm]
$E$	Young’s modulus of elasticity	$1,93 \cdot 10^5$ [N/mm <sup>2</sup> ]
$\nu$	Poisson’s ration of the material	~0,3
$hd$	Diaphragm thickness	0,025[mm]/0,050[mm]
$H$	Corrugation depth	0,3 [mm]
$n$	Number of corrugation	5

In this paper, the toroidal corrugated membranes was examined with a distance of corrugations from the solid center, respectively: 6; 9.5; 13; 16.5 and 20 mm. The idea is to perform a comparative analysis of the sensitivity of the sinusoid membrane to the toroidal membrane. The height of the formed corrugation in both cases is 0.3mm.

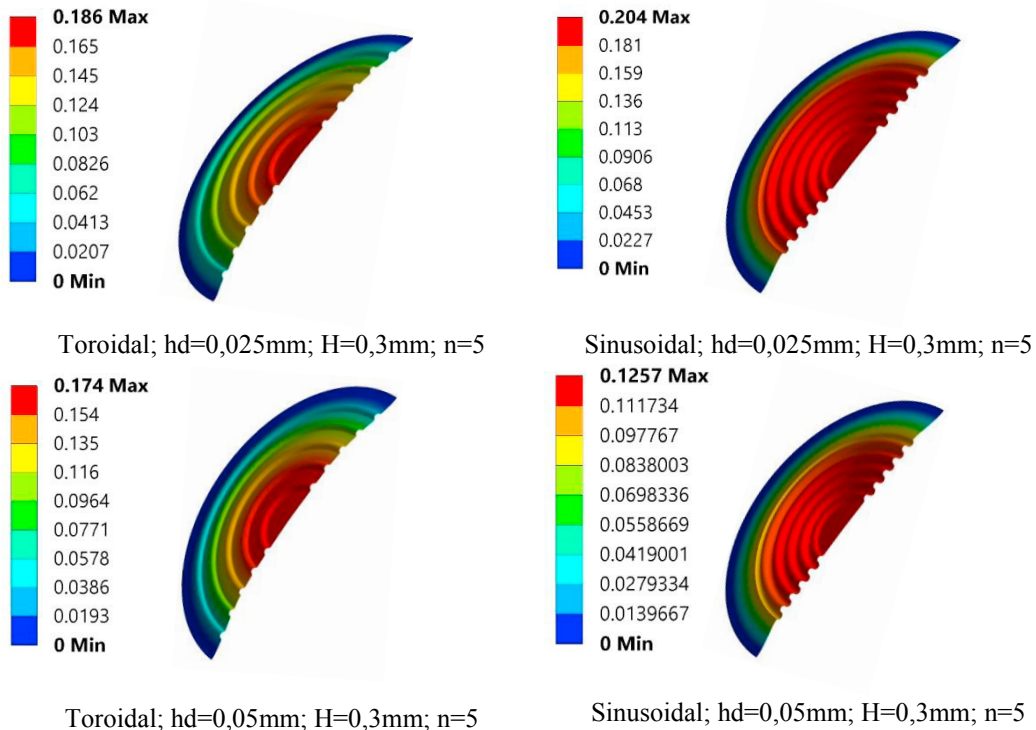

Fig. 2. FE analysis for corrugated diaphragm 24mm diameter

For the analysis of the relation pressure/deflection it was used FE method. The theory of shells was used in the analysis of the corrugated diaphragm (Wierzbicki and Abramowicz, 1983). For calculation, characteristics of AISI 316 were considered: 1) density ( $7,96 \cdot 10^3 \text{ kg/m}^3$ ), 2) tensile strength (460-860 MPa), 3) yield strength (205 MPa), 4) hardness (160-190 RB) 5) Young's modulus ( $2.1 \cdot 10^{11} \text{ Pa}$ ). The finite element method (Zou et al., 1997; Andrianov et al., 2017) was used in the calculation of the deflection. The simulation results for the maximum flow stress of the mentioned material ( $2.05 \cdot 10^8 \text{ Pa}$ ) are shown in Fig. 2.

FE analysis shows that if the thinner diaphragm is increased, the sensitivity of the diaphragm increases, which can lead to degradation or even damage to the diaphragm at high pressure. The analysis confirmed that the change in the thickness of the fold at the same depth significantly changes the characteristics of the profiled membrane, as can be seen from Fig. 2.

#### 4. Experimental measurement

The experimental measurements of the diaphragm of the toroidal and sinusoidal cross section were performed. On the one hand, a comparative analysis of numerical and experimental results is performed, while on the other hand recommendations are given on how to improve and optimize the diaphragm. The diaphragm was placed in the clamping tool (see Fig. 3) and was tested at pressures of 10 mbar to 60 mbar.



Fig. 3. Diaphragm test assembly: 1 quick coupling; 2 – body of measurement chamber with the diaphragm

The pressure setting is controlled by the Mensor APC 600 pressure calibrator. The calibrator applied and maintained the pressure with the accuracy of 0.1mbar. The Iskra NP37 electronic comparator was used to measure the deflection, with the accuracy of the vertical shift of 0.001mm. The needle on the comparator has a certain mass and exerts additional pressure on the surface of the diaphragm. During the measurement, additional needle pressure is compensated by cyclic measurement and diaphragm insertion. By giving the pressure with the Mensor, diaphragm rises and the needle registers a sweep, or a deflection.

Fig. 4 shows a scheme of the experimental measurement of the diaphragm's deflection.

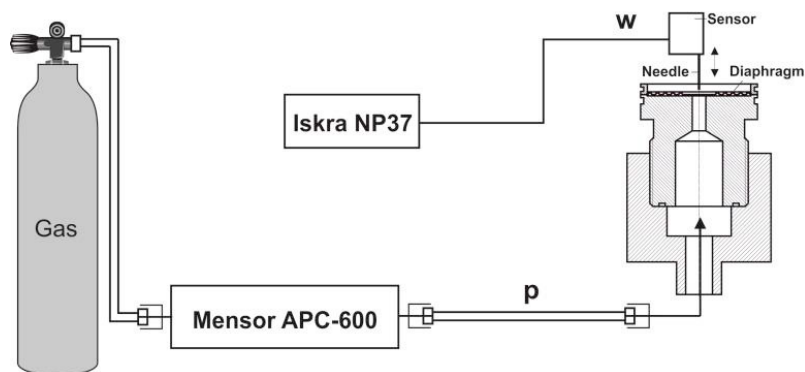

Fig. 4. Diaphragm deflection scheme

#### 5. Results and discussion

The sensitivity of the corrugated diaphragm depends on several parameters: the width and height of the fold, shape and density of the fold. A comparison of the obtained results of the toroidal and sinusoidal diaphragms with

the variation in the thickness of the material 0.025mm/0.05mm can be concluded that the toroidal diaphragm has close to two times the smaller angle in relation to the sinusoidal diaphragm. During the experimental work, a measurement uncertainty of 10 mbar was determined, which can depend on the needle's weight itself and on the release of a new undeveloped diaphragm. Also, as a medium, a gas that is compressible is used, which influences the slower and non-linear response of the diaphragm. Due to these measurement uncertainties, measurements were made in several cycles, in order to obtain the most linear results.

## 6. Conclusion

- In this paper the sensitivity of toroidal and sinusoidal corrugated diaphragms was studied.
- Based on the results, the sinusoidal diaphragm has almost twice as many fits compared to the toroidal diaphragm.
- Experimental results indicate that there are certain deflections in the diaphragm response, primarily due to the use of an over stretched diaphragm and the compression with a compressible medium.
- The corrugated toroidal diaphragm thickness 0.025mm has a good linear spring feature and gives a good response for pressures of 10mbar ÷ 100mbar.
- The oil should be applied instead of gas, in order to obtain a faster system response.

## Acknowledgement

This work is a part of current projects TR-35035 and TR-32008 funded by Ministry of Education, Science and Technological Development of the Republic of Serbia.

## References

- Andrianov, I. V., Diskovsky, A. A., Syerko, E., 2017. Optimal design of a circular corrugated diaphragm using the homogenization approach. *Mathematics and Mechanics of Solids*, 22, 283-303.
- Dissanayake, D. W., Al-Sarawi, S., Lu, T. F., Abbott, D., 2009. Finite element modelling of surface acoustic wave device based corrugated microdiaphragms. *Smart materials and structures*, 18, 095030.
- Gawade, S. S., Chavan, D. S., 2013. Load-deflection analysis of flat and corrugated stainless steel diaphragms by theoretical and finite element method. *International Journal of Engineering Research and Applications (IJERA)*, 3, 799-802.
- Giovanni, D., 1982. Flat and corrugated diaphragm design handbook. In: CRC Press.
- Jerman, J. H., 1990. The fabrication and use of micromachined corrugated silicon diaphragms. *Sensors and Actuators A: Physical*, 23, 988-992.
- Kressmann, R., Klaiber, M., Hess, G., 2002. Silicon condenser microphones with corrugated silicon oxide/nitride electret membranes. *Sensors and Actuators A: Physical*, 100, 301-309.
- van Mullem, C. J., Gabriel, K. J., Fujita, H., 1991. Large-Deflection Performance of Surface Micromachined Corrugated Diaphragms, Proc of 6th International Conference on Solid-State Sensors and Actuators, San Fransisco, USA, 1014-1017.
- Scheeper, P. R., Olthuis, W., Bergveld, P., 1994. The design, fabrication, and testing of corrugated silicon nitride diaphragms. *Journal of microelectromechanical systems*, 3, 136-142.
- Spiering, V. L., Bouwstra, S., Burger, J. F., Elwenspoek, M., 1993. Membranes fabricated with a deep single corrugation for package stress reduction and residual stress relief. *Journal of micromechanics and microengineering*, 3, pp. 243.
- Wierzbicki, T., Abramowicz, W., 1983. On the crushing mechanics of thin-walled structures. *Journal of Applied mechanics*, 50, 727-734.
- Zou, Q., Wang, Z., Lin, R., Yi, S., Gong, H., Lim, M., Liu, L., 1997. A study on corrugated diaphragms for high-sensitivity structures. *Journal of Micromechanics and Microengineering*, 7, 310.