

Optimal Movement of the Suspended Payload

Uglješa Bugarić, Ph.D.

Professor
University of Belgrade
Faculty of Mechanical Engineering

Josif Vuković, Ph.D.

Professor
University of Belgrade
Faculty of Mechanical Engineering

Dušan Glišić, B.Sc.

Siemens IT Solutions and Services
Pariske komune 22, Belgrade

Dušan Petrović, Ph.D.

Professor
University of Belgrade
Faculty of Mechanical Engineering

This paper presents one of the possible ways to optimize the movement of the suspended payload. Application of presented optimization procedure is shown on grab crane devices such as unloading bridge and harbour crane. The optimization procedure is divided into two phases. The first phase is optimization of the cargo and grab (suspended payload) movement. The second phase is determination of movement, of the grab crane device mechanisms, upon obtained optimal path and parameters of cargo and grab (payload) movement. Shape of presented mathematical model makes possible direct application of optimal control theory methods i.e. optimization of the payload movement is determined using Pontryagin's maximum principle. The basic aim of optimization is to attain the minimal working (unloading) cycle, spending of energy and material dissipation during the grab discharging. All relevant expressions are derived analytically..

Keywords: optimization, unloading cycle, harbour crane, unloading bridge, maximum principle.

1 INTRODUCTION

The terminal for bulk cargo unloading presents the organization of different activities, connected with control and handling of material flow from the vessel to the transport or the storage system of the technological installations, which provides maximal servicing of vessels with minimum expenses.

Unloading devices present knot points of unloading terminal, and in the greatest number of cases the bottle necks, so their functioning is the basic prerequisite for optimal work of the whole unloading system.

The unloading (working) cycle of grab crane devices consist of: material grabbing from the vessel, grab and cargo transfer from the vessel to the receiving hopper, grab discharging and empty grab return transfer from the receiving hopper to the vessel. Full automation of unloading process of the grab crane devices, is possible but it is very expensive. On the other side the crane operator couldn't repeat the optimal unloading cycle in the longer time period. The only practical feasible solution is to introduce the half-automatic unloading cycle which consists of the manual part, where the crane operator control the grab movement, and of the automatic part in which the computer controls the grab movement according to given algorithm.

The manual part of half-automatic unloading cycle consists of the empty grab lowering to the material surface in the vessel, from one of the three points of the end of automatic part of the unloading cycle (fig. 1a, 1b.), material grabbing and grab hoisting with cargo to one of the three points of the beginning of automatic part of the unloading cycle. Automatic part of half-

automatic unloading cycle consists of grab transfer from one of the three points of the beginning of automatic part of the unloading cycle to the receiving hopper, grab discharging and empty grab return transfer from the hopper to the one of the three possible points of the end of automatic part of the unloading cycle. The position of three points, which presents the beginning/end of automatic part of half-automatic unloading cycle, is virtual and depends on given geometry of the system, river water level, material level in the vessel, etc. [1]

Optimization of the half-automatic unloading cycle has sense only in its automatic part where computer controls the grab movement.

Optimization procedure, which will be presented, is universal for all unloading grab crane devices and it will be applied on most common unloading grab crane devices such as: harbour crane and unloading bridge.

2 MATHEMATICAL MODELS

Fig. 1a and Fig. 1b show a simplified crane devices and cargo moving scheme on the basis of which the mathematical models are set. Assumption is that the rope in the initial time is in the vertical position with defined initial length, and grab position could be one of the three possible. This assumption corresponds to the time immediately before the beginning of automatic part of the unloading cycle.

2.1 Mathematical model of the harbor crane

A simplified scheme of the harbour crane is shown on Fig. 1a. Generalized coordinates are: φ – angle of the jib, θ – angle of the lever–luffing. A review of indications used in the mathematical model: g - gravity acceleration, m_1 – mass of the jib, m_2 – mass of the lever–luffing, m – grab and cargo mass, l – instantaneous rope length, l_1 – length of the jib, l_2 –

Received: November 2012, Accepted: May 2013

Correspondence to: Uglješa Bugarić
Faculty of Mechanical Engineering,
Kraljice Marije 16, 11120 Belgrade 35, Serbia
E-mail: ubugaric@mas.bg.ac.rs

length of the lever-luffing, ψ – rope angle, x_k – distance between vessel and hopper, z_k – height distance between the beginning/end point of automatic part of half-automatic unloading cycle and discharging point of the grab, M_A – driving momentum acting on jib, M_B – driving momentum acting on lever-luffing, F – force in the rope, l_{c1} – distance between point A and centre of gravity of a jib, l_{c2} – distance between point B and centre of gravity of a lever-luffing, J_A – inertial momentum of a jib upon the axis through point A, J_{c2} – inertial momentum of a lever-luffing upon the axis through the centre of gravity of a lever-luffing. It is adopted that centres of gravity of a jib and a lever-luffing are on straight lines between points A and B and B and C respectively. Driving momentum's M_A and M_B are reduced to points A and B. Obtaining real driving momentum's requires decomposing of the whole driving structure of the crane which is not the same for all harbour cranes (depends on manufacturer), and it is not the subject of this work. Forces in rope that connects lever-luffing and construction of harbour crane are taken into consideration by reducing real driving momentums into points A and B.

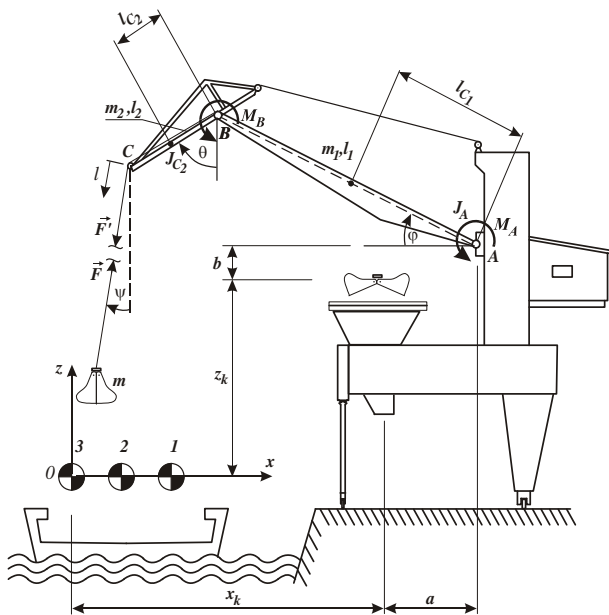

Figure 1a. Simplified scheme of the harbour crane [2]

Differential equations which describe movement of harbour crane mechanisms are:

$$\begin{aligned} & (J_A + m_2 l_1^2) \ddot{\varphi} - [m_2 l_1 l_{c2} \sin(\varphi - \theta)] \ddot{\theta} + \\ & [m_2 l_1 l_{c2} \cos(\varphi - \theta)] \dot{\theta}^2 = \\ & = M_A - m_1 g l_{c1} \cos \varphi - m_2 g l_1 \cos \varphi - \\ & - F l_1 \cos(\psi - \varphi), \end{aligned} \quad (1a)$$

$$\begin{aligned} & - [m_2 l_1 l_{c2} \sin(\varphi - \theta)] \ddot{\varphi} + (J_{c2} + m_2 l_{c2}^2) \ddot{\theta} - \\ & [m_2 l_1 l_{c2} \sin(\varphi - \theta)] \dot{\varphi}^2 = \\ & = M_B + m_2 g l_{c2} \sin \theta + F l_2 \sin(\psi - \theta). \end{aligned}$$

2.2 Mathematical model of the unloading bridge

A simplified scheme of the unloading bridge is shown in Fig. 1b. Generalized coordinate is: ξ – instantaneous centre of gravity position of the crane trolley. Review of indications used in the mathematical model: ψ – rope angle, g – gravity acceleration, m – grab and cargo mass, x_k – distance between vessel and hopper, z_k – height distance between beginning/end point of automatic part of half-automatic unloading cycle and discharging point of the grab, z_t – height distance between the beginning/end point of automatic part of half-automatic unloading cycle and rope suspension point, m_1 – mass of the crane trolley, l – instantaneous rope length, F_d – driving force of trolley, F – force in the rope.

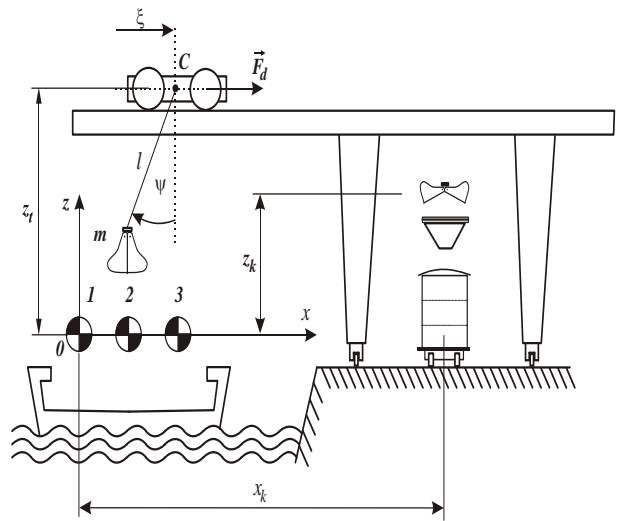

Figure 1b. Simplified scheme of the unloading bridge [3]

Differential equation which describes movement of unloading bridge trolley is:

$$m_1 \cdot \ddot{\xi} = F_d - F \cdot \sin \psi \quad (1b)$$

where: $\xi = x + l \cdot \sin \psi$, $l = (z_t - z) / \cos \psi$, i.e. $\xi = x + (z_t - z) \cdot \operatorname{tg} \psi$.

3 OPTIMIZATION PROCEDURE

The main objectives of the optimization process are minimal working (unloading) cycle, minimal rope incline angle, minimal dissipation of material and therefore minimal spending of energy needed for the movement of grab crane devices.

The optimization procedure of the grab crane devices (harbour crane and unloading bridge) working cycle will be divided into two phases. The first phase is optimization of the cargo and grab (suspended payload) movement. The second phase is the determination of movement, of the grab crane device mechanisms, upon obtained optimal path and parameters of cargo and grab (payload) movement. According to that movement of the crane mechanisms and movement of the grab and cargo will be observed separately.

3.1 Optimization of the cargo and grab movement – I phase of optimization

The movement of the grab and cargo is suitable to analyze in the coordinate system xOz (Fig. 2). At the beginning of the movement grab and cargo are at point O .

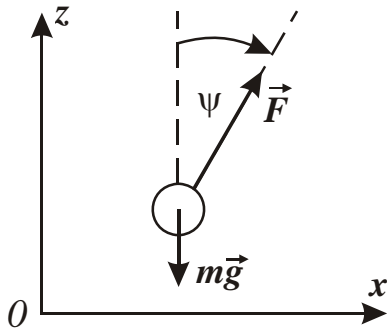

Figure 2. Forces which acts on the grab and cargo

In that case differential equations which describe the movement of grab and cargo are:

$$m\ddot{x} = F \sin \psi, \quad m\ddot{z} = F \cos \psi - mg, \quad \frac{F}{m} = S, \quad (2)$$

$$\ddot{x} = S \sin \psi, \quad \ddot{z} = S \cos \psi - g,$$

Grab and cargo, for the time interval known in advance $[0, t_c]$, from initial state:

$$t = 0, \quad x(0) = 0; \quad \dot{x}(0) = 0; \\ z(0) = 0; \quad \dot{z}(0) = 0; \quad (3)$$

should come to ending state:

$$t = t_c, \quad x(t_c) = x_k; \quad \dot{x}(t_c) = 0; \\ z(t_c) = z_k; \quad \dot{z}(t_c) = 0; \quad (4)$$

with limitation that grab and cargo should pass through point $(x_k/2, z_k)$ and after that continue to move horizontally i.e.

$$x(\tau) = x_k/2; \quad z(\tau) = z_k; \quad z(\tau \leq t \leq t_c) = z_k \quad (5)$$

where the moment of time τ is not known in advance.

If such functions $\psi(t), S(t) > 0$ can be found, together with following conditions:

$$\psi(0) = 0; \quad \dot{\psi}(0) = 0; \quad S(0) = g \\ \psi(t_c) = 0; \quad \dot{\psi}(t_c) = 0; \quad S(t_c) = g, \quad (6)$$

in a way that appropriate solutions of (2) fulfils conditions (3), (4) and (5), the whole system can be controlled.

By increasing the order of differential equations (2) those equations can be written as:

$$\ddot{x} = \dot{S} \sin \psi + S \dot{\psi} \cos \psi \\ \ddot{z} = \dot{S} \cos \psi - S \dot{\psi} \sin \psi \quad (7)$$

and conditions (6) can be written as:

$$\ddot{x}(0) = 0; \quad \ddot{x}(t_c) = 0; \quad \ddot{z}(0) = 0; \\ \ddot{x}(t_c) = 0; \quad \ddot{x}(t_c) = 0; \quad \ddot{z}(t_c) = 0. \quad (8)$$

In that way the task of controlled movement of the grab and cargo can be stated in a following form:

$$x^{IV} = u_x, \quad z^{IV} = u_z \quad (9)$$

$$x(0) = 0; \quad \dot{x}(0) = 0; \quad \ddot{x}(0) = 0; \quad \ddot{x}(0) = 0; \\ z(0) = 0; \quad \dot{z}(0) = 0; \quad \ddot{z}(0) = 0; \\ x(t_c) = x_k; \quad \dot{x}(t_c) = 0; \quad \ddot{x}(t_c) = 0; \quad \ddot{x}(t_c) = 0; \quad (10) \\ z(t_c) = z_k; \quad \dot{z}(t_c) = 0; \quad \ddot{z}(t_c) = 0; \\ x(\tau) = x_k/2; \quad z(\tau) = z_k; \quad z(\tau \leq t \leq t_c) = z_k$$

where u_x and u_z are allowed values of control which belongs to an open set.

Initial condition for \ddot{z} is not set in order to ensure movement in z – direction at the beginning of the movement, while ending condition for \ddot{z} is automatically fulfilled due to transverse condition.

According to (2) and (7) equations (9) and conditions (11) are equivalent with equations (2) and conditions (3), (4), (5) and (6).

By introducing new variables $y_i (i = 1, 2, \dots, 8)$ where $y_1 = x, y_2 = \dot{x}, y_3 = \ddot{x}, y_4 = \ddot{x}, y_5 = z, y_6 = \dot{z}, y_7 = \ddot{z}$ and $y_8 = \ddot{z}$, the system of equations (2) and (7) can be presented as:

$$y_1 = x, \quad y_2 = \dot{x}, \\ y_3 = S \cdot \sin \psi, \quad y_4 = \dot{S} \cdot \sin \psi + S \cdot \dot{\psi} \cdot \cos \psi \\ y_5 = z, \quad y_6 = \dot{z}, \\ y_7 = S \cdot \cos \psi - g, \quad y_8 = \dot{S} \cdot \cos \psi - S \cdot \dot{\psi} \cdot \sin \psi \quad (11)$$

According to (11), control (9) and conditions (10) can be written in the following form:

$$\dot{y}_1 = y_2; \quad \dot{y}_2 = y_3; \quad \dot{y}_3 = y_4; \quad \dot{y}_4 = u_x; \\ \dot{y}_5 = y_6; \quad \dot{y}_6 = y_7; \quad \dot{y}_7 = y_8; \quad \dot{y}_8 = u_z \quad (12)$$

or

$$\dot{y}_1 = \dot{x}; \quad \dot{y}_2 = S \cdot \sin \psi; \\ \dot{y}_3 = \dot{S} \cdot \sin \psi + S \cdot \dot{\psi} \cdot \cos \psi; \quad \dot{y}_4 = u_x; \\ \dot{y}_5 = \dot{z}; \quad \dot{y}_6 = S \cdot \cos \psi - g; \\ \dot{y}_7 = \dot{S} \cdot \cos \psi - S \cdot \dot{\psi} \cdot \sin \psi; \quad \dot{y}_8 = u_z$$

and

$$y_1(0) = 0; \quad y_2(0) = 0; \quad y_3(0) = 0; \quad y_4(0) = 0; \\ y_5(0) = 0; \quad y_6(0) = 0; \quad y_7(0) = 0; \\ y_1(t_c) = x_k; \quad y_2(t_c) = 0; \quad y_3(t_c) = 0; \quad y_4(t_c) = 0; \quad (13) \\ y_5(t_c) = z_k; \quad y_6(t_c) = 0; \quad y_7(t_c) = 0; \\ y_1(\tau) = x_k/2; \quad y_5(\tau) = z_k; \quad y_5(\tau \leq t \leq t_c) = z_k$$

or

$$x(0) = 0, \quad \dot{x}(0) = 0, \quad \ddot{x}(0) = 0, \quad \ddot{x}(0) = 0, \\ z(0) = 0, \quad \dot{z}(0) = 0, \quad \ddot{z}(0) = 0, \\ x(t_c) = x_k, \quad \dot{x}(t_c) = 0, \quad \ddot{x}(t_c) = 0, \quad \ddot{x}(t_c) = 0, \\ z(t_c) = z_k, \quad \dot{z}(t_c) = 0, \quad \ddot{z}(t_c) = 0, \\ x(\tau) = x_k/2, \quad z(\tau \leq t \leq t_c) = z_k$$

which allowed direct application of Pontryagin's maximum principle. Values u_x and u_z are control values in x and z direction. [4-6].

During the grab and cargo transfer from vessel to hopper and vice versa minimal rope incline angle as well as no more than one oscillation of the grab and cargo are required. Beside that, changes in rope load as a result of grab and cargo transfer should be reduced to minimum. In that sense, the condition of optimality (14) presents good enough measure of behaviour of those values

$$J = \int_0^{t_c} \frac{1}{2} (y_3^2 + y_4^2 + u_x^2 + y_8^2) dt \rightarrow \inf \quad (14)$$

or

$$J = \int_0^{t_c} \frac{1}{2} [S^2 \cdot (\sin^2 \psi + \dot{\psi}^2) + \dot{S}^2 + u_x^2] dt \rightarrow \inf$$

Differential equations (12) and conditions (13) together with the condition of optimality (14) present the task of optimal control.

In another words, on the basis of equation system (2), it can be concluded that rope inclination and angular velocity of rope have greater influence on the movement in x -direction i.e. on values y_3 , y_4 and u_x , while change of rope load has greater influence on movement in z -direction i.e. on the value y_8 . So, minimal value of (14) fulfils required demands and represents optimality criterion for discussed problem and it provides that the values of control and rope incline angle not become so big, minimal number of oscillations, continuouseness of the force in rope, uniform work, etc.

The problem defined by the relations (12), (13) and (14) is reduced to the form which makes possible the direct application of maximum principle. For these reasons, considering (12) and (14), the function is established:

$$H = -\frac{1}{2} (y_3^2 + y_4^2 + u_x^2 + y_8^2) + \lambda_1 y_2 + \lambda_2 y_3 + \lambda_3 y_4 + \lambda_4 u_x + \lambda_5 y_6 + \lambda_6 y_7 + \lambda_7 y_8 + \lambda_8 u_z \quad (15)$$

or

$$H = -S^2 \sin^2 \psi - S^2 \sin \psi \cos \psi - \frac{1}{2} u_x^2 - \frac{1}{2} \dot{S} \cos^2 \psi + S \dot{S} \dot{\psi} \sin \psi \cos \psi - \frac{1}{2} S \dot{\psi}^2 + \lambda_1 \dot{x} + \lambda_2 S \sin \psi + \lambda_3 S \sin \psi + \lambda_3 S \dot{\psi} \cos \psi + \lambda_4 u_x + \lambda_5 \dot{z} + \lambda_6 S \cos \psi - \lambda_6 g - \lambda_7 \dot{S} \cos \psi - \lambda_7 S \dot{\psi} \sin \psi + \lambda_8 u_z$$

where the values λ_i satisfied the differential equations system:

$$\dot{\lambda}_i = -\frac{\partial H}{\partial y_i} \quad (i=1, \dots, 8),$$

$$\begin{aligned} \dot{\lambda}_1 &= 0; & \dot{\lambda}_2 &= -\lambda_1; & \dot{\lambda}_3 &= y_3 - \lambda_2; \\ \dot{\lambda}_4 &= y_4 - \lambda_3; & \dot{\lambda}_5 &= 0; & \dot{\lambda}_6 &= -\lambda_5; \\ \dot{\lambda}_7 &= -\lambda_6; & \dot{\lambda}_8 &= y_8 - \lambda_7. \end{aligned} \quad (16)$$

According to the theorem of the principle of maximum, function (15) for the optimal solution has the maximal value. According to the needing condition of extreme:

$$\frac{\partial H}{\partial u_x} = 0 \quad \text{and} \quad \frac{\partial H}{\partial u_z} = 0 \quad (17)$$

the controls in x and z directions are obtained:

$$\begin{aligned} -u_x + \lambda_4 &= 0 \rightarrow u_x = \lambda_4; \\ \lambda_8 &= 0 \rightarrow \dot{\lambda}_8 = 0 \rightarrow y_8 = \lambda_7 \end{aligned} \quad (18)$$

The following transverse conditions should be added to conditions (13):

$$\lambda_8(0) = 0; \quad \lambda_8(t_c) = 0$$

what is trivially fulfilled in (18).

The structure of differential equation systems (12) and (16) shows that optimization of grab and cargo movement in x and z direction can be done separately. System of differential equations for optimization grab and cargo movement in x direction has the following form:

$$\begin{aligned} \dot{y}_1 &= y_2; & \dot{y}_2 &= y_3; & \dot{y}_3 &= y_4; \\ \dot{y}_4 &= \lambda_4; \\ \dot{\lambda}_1 &= 0; & \dot{\lambda}_2 &= -\lambda_1; & \dot{\lambda}_3 &= y_3 - \lambda_2; \\ \dot{\lambda}_4 &= y_4 - \lambda_3 \end{aligned} \quad (19)$$

or

$$\begin{aligned} y_2 &= \dot{x}; & y_3 &= S \sin \psi; \\ y_4 &= S \sin \psi + S \dot{\psi} \cos \psi; & \dot{y}_4 &= \lambda_4; \\ \dot{\lambda}_1 &= 0; & \dot{\lambda}_2 &= -\lambda_1; & \dot{\lambda}_3 &= S \sin \psi - \lambda_2; \\ \dot{\lambda}_4 &= S \sin \psi + S \dot{\psi} \cos \psi - \lambda_3 \end{aligned}$$

Boundary conditions are:

$$\begin{aligned} t = 0, & & y_1(0) &= 0; & y_2(0) &= 0; \\ & & y_3(0) &= 0; & y_4(0) &= 0; \\ t = t_c, & & y_1(t_c) &= x_k; & y_2(t_c) &= 0; \\ & & y_3(t_c) &= 0; & y_4(t_c) &= 0. \end{aligned} \quad (20)$$

The system of differential equations for optimization of the grab and cargo movement in z direction has the following form:

$$\begin{aligned} \dot{y}_5 &= y_6; & \dot{y}_6 &= y_7; & \dot{y}_7 &= y_8; & \dot{y}_8 &= -\lambda_6; \\ \dot{\lambda}_5 &= 0; & \dot{\lambda}_6 &= -\lambda_5; & \dot{\lambda}_7 &= -\lambda_6; & \dot{\lambda}_8 &= 0. \end{aligned} \quad (21)$$

or

$$\begin{aligned}
y_6 &= \dot{z}; \\
y_7 &= S \cos \psi - g; \\
y_8 &= \dot{S} \cos \psi - S \dot{\psi} \sin \psi; \\
u_z &= -\lambda_6; \\
\dot{\lambda}_5 &= 0; \\
\dot{\lambda}_6 &= -\lambda_5; \\
\dot{\lambda}_7 &= -\lambda_6; \\
\dot{\lambda}_8 &= 0.
\end{aligned}$$

Boundary conditions are:

$$\begin{aligned}
t = 0, \quad y_5(0) = 0; \quad y_6(0) = 0; \\
\quad \quad \quad y_7(0) = 0; \quad \lambda_8(0) = 0; \\
t = \tau, \quad y_5(\tau) = z_k; \quad y_6(\tau) = 0; \\
\quad \quad \quad y_7(\tau) = 0; \quad \lambda_8(\tau) = 0; \\
\tau \leq t \leq t_c \quad y_5(\tau) = z_k; \quad y_6(t) = 0; \\
\quad \quad \quad y_7(t) = 0; \quad \lambda_8(t) = 0.
\end{aligned} \quad (22)$$

Each system of differential equations systems (19) and (21) defined on this way, with condition (20) and (22) presents the two-point boundary value problem. Due to configuration of the differential equation systems (19) and (21) each of them can be solved analytically.

3.2 Analytical solutions

According to differential equation systems (12) and (19) following relations can be established: (movement in x - direction)

$$\begin{aligned}
u_x &= \lambda_4, \quad \lambda_1 = L_1, \\
\lambda_2 &= -L_1 t + L_2, \\
\lambda_3 &= y_2 + \frac{1}{2} L_1 t^2 - L_2 t + L_3, \\
\lambda_4 &= y_3 - y_1 - \frac{1}{6} L_1 t^3 + \frac{1}{2} L_2 t^2 - L_3 t + L_4, \\
\dot{y}_4 &= \dot{y}_2 - y_1 = -\frac{1}{6} L_1 t^3 + \frac{1}{2} L_2 t^2 - L_3 t + L_4.
\end{aligned}$$

Finally, differential equation system (19) can be reduced to one fourth order differential equation:

$$y_1^{IV} - \ddot{y}_1 + y_1 = -\frac{1}{6} L_1 t^3 + \frac{1}{2} L_2 t^2 - L_3 t + L_4 \quad (23)$$

where L_1, L_2, L_3, L_4 are arbitrary constants.

The solution of previous differential equation has the following form:

$$\begin{aligned}
y_1 = x &= (A_1 e^{\sqrt{3}t/2} + B_1 e^{-\sqrt{3}t/2}) \cos(t/2) + \\
&+ (C_1 e^{\sqrt{3}t/2} + D_1 e^{-\sqrt{3}t/2}) \sin(t/2) + \\
&+ E_1 t^3 + F_1 t^2 + \\
&+ G_1 t + H_1
\end{aligned}$$

Differentiating previous expression per t expressions for y_2, y_3, y_4 and $\dot{y}_4 = u_x$ are obtained as:

$$\begin{aligned}
y_2 = \dot{x} &= 0.5 \left[\sqrt{3}(-B_1 + A_1 e^{\sqrt{3}t}) \cos(t/2) + \right. \\
&+ (D_1 + C_1 e^{\sqrt{3}t}) \cos(t/2) - \\
&- (B_1 + A_1 e^{\sqrt{3}t}) \sin(t/2) + \\
&+ \left. \sqrt{3}(-D_1 + C_1 e^{\sqrt{3}t}) \sin(t/2) \right] e^{-\sqrt{3}t/2} + \\
&+ 3E_1 t^2 + 2F_1 t + G_1
\end{aligned}$$

$$\begin{aligned}
y_3 = \ddot{x} &= 0.5 \left[(B_1 + A_1 e^{\sqrt{3}t}) \cos(t/2) + \right. \\
&+ \sqrt{3}(-D_1 + C_1 e^{\sqrt{3}t}) \cos(t/2) + \\
&+ \sqrt{3}(B_1 - A_1 e^{\sqrt{3}t}) \sin(t/2) + \\
&+ (D_1 + C_1 e^{\sqrt{3}t}) \sin(t/2) \left. \right] e^{-\sqrt{3}t/2} + \\
&+ 6E_1 t + 2F_1
\end{aligned}$$

$$\begin{aligned}
y_4 = \ddot{\ddot{x}} &= \left[D_1 \cos(t/2) + C_1 e^{\sqrt{3}t} \cos(t/2) - \right. \\
&- A_1 e^{\sqrt{3}t} \sin(t/2) - B_1 \sin(t/2) \left. \right] e^{-\sqrt{3}t/2} + 6E_1
\end{aligned}$$

$$\begin{aligned}
\dot{y}_4 = x^{IV} = u_x &= 0.5 \left[-(B_1 + A_1 e^{\sqrt{3}t}) \cos(t/2) + \right. \\
&+ \sqrt{3}(-D_1 + C_1 e^{\sqrt{3}t}) \cos(t/2) + \\
&+ \sqrt{3}(B_1 - A_1 e^{\sqrt{3}t}) \sin(t/2) - \\
&- (D_1 + C_1 e^{\sqrt{3}t}) \sin(t/2) \left. \right] e^{-\sqrt{3}t/2}
\end{aligned}$$

where $A_1, B_1, C_1, D_1, E_1, F_1, G_1, H_1$ are constants which are determined upon boundary conditions (3) and (4).

For the movement in z - direction according to differential equation systems (12) and (21) the following relations can be established:

$$\begin{aligned}
u_z &= -\lambda_6, \quad \lambda_5 = L_5, \quad \lambda_6 = -L_5 t + L_6, \\
\dot{y}_8 &= \dot{\lambda}_7, \quad \dot{y}_8 = -\lambda_6, \quad \dot{y}_8 = L_5 t - L_6
\end{aligned}$$

where L_5, L_6 are arbitrary constants.

Substituting $(L_5, -L_6)$ with (A_2, B_2) the required expressions for the movement in z - direction are obtained as:

$$\begin{aligned}
\dot{y}_8 = z^{IV} &= u_z = A_2 t + B_2 \\
y_8 = \ddot{z} &= \frac{1}{2} A_2 t^2 + B_2 t + C_2 \\
y_7 = \ddot{z} &= \frac{1}{6} A_2 t^3 + \frac{1}{2} B_2 t^2 + C_2 t + D_2 \\
y_6 = \dot{z} &= \frac{1}{24} A_2 t^4 + \frac{1}{6} B_2 t^3 + \frac{1}{2} C_2 t^2 + D_2 t + E_2 \\
y_5 = z &= \frac{1}{120} A_2 t^5 + \frac{1}{24} B_2 t^4 + \frac{1}{6} C_2 t^3 + \frac{1}{2} D_2 t^2 + \\
&+ E_2 t + F_2
\end{aligned}$$

where $A_2, B_2, C_2, D_2, E_2, F_2$ are constants which are determined upon boundary conditions (13).

Directly from differential equation system (2) the expressions for ψ and S are obtained as:

$$\psi = \arctg \frac{\ddot{x}}{\ddot{z} + g}, \quad S = \sqrt{\dot{x}^2 + (\ddot{z} + g)^2}.$$

Fig. 3a – Fig. 3f show results of grab and cargo optimization process per time. Those results are: change of coordinates x and z per time (Fig. 3a); change of grab and cargo velocity \dot{x} , acceleration \ddot{x} , jerk \dddot{x} and control $x^{IV} = u_x$ in x -direction per time (Fig. 3b); change of grab and cargo velocity \dot{z} , acceleration \ddot{z} , jerk \dddot{z} and control $z^{IV} = u_z$ in z -direction per time (Fig. 3c); change of rope incline angle ψ and angular velocity $\dot{\psi}$ of grab and cargo per time (Fig. 3d); change of force in the rope F/m i.e. S per time (Fig. 3e); and optimal path of the grab and cargo $z = f(x)$ (Fig. 3f).

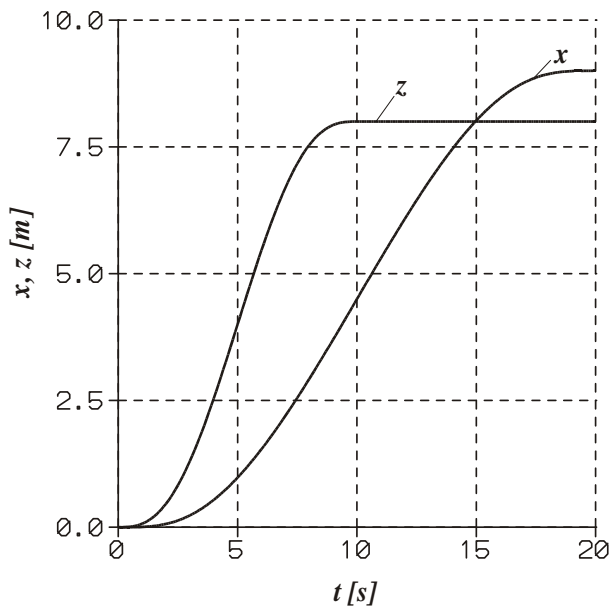

Figure 3a. Change of the optimised values – coordinates x, z

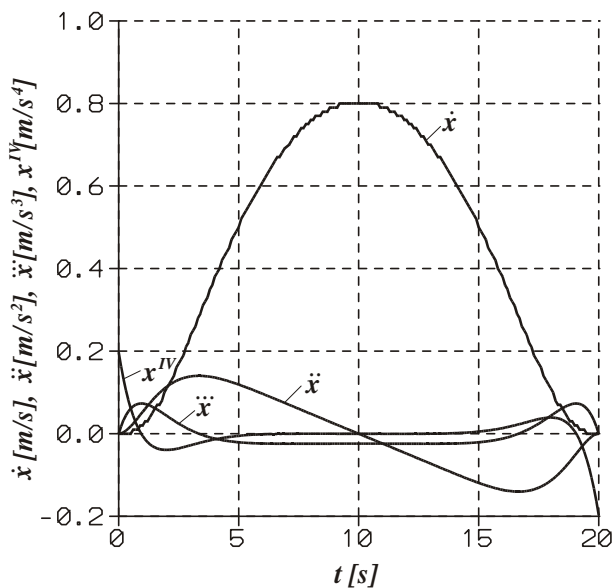

Figure 3b. Change of the optimised values – velocity, acceleration, jerk and control in x -direction

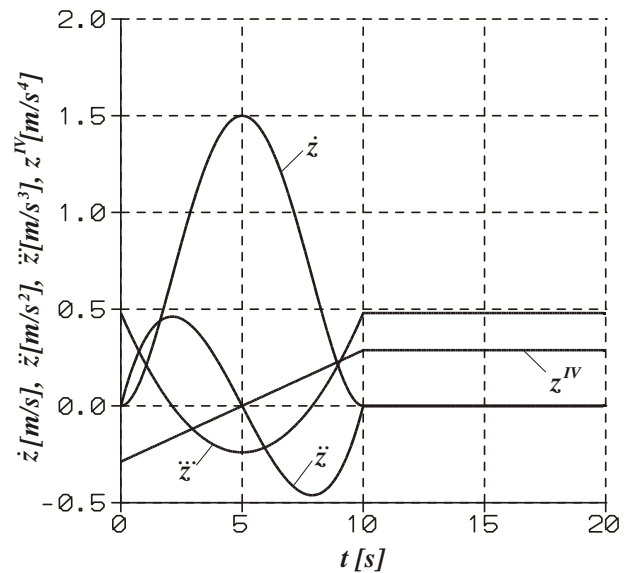

Figure 3c. Change of the optimised values – velocity, acceleration, jerk and control in z -direction

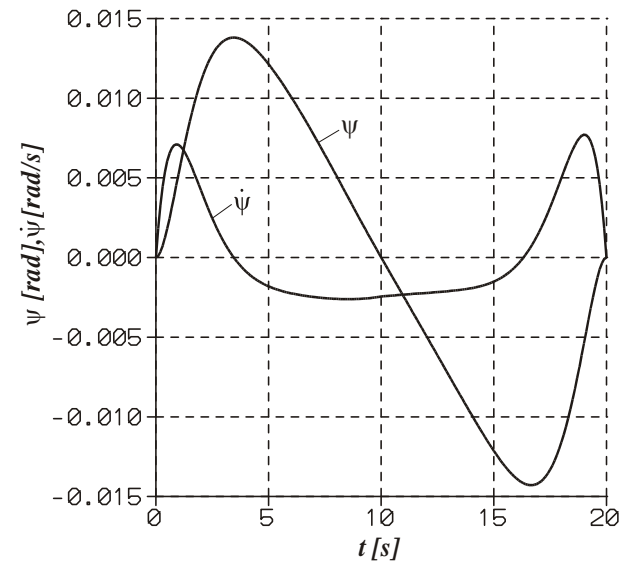

Figure 3d. Change of the optimised values - rope incline angle and angular velocity of grab and cargo per time

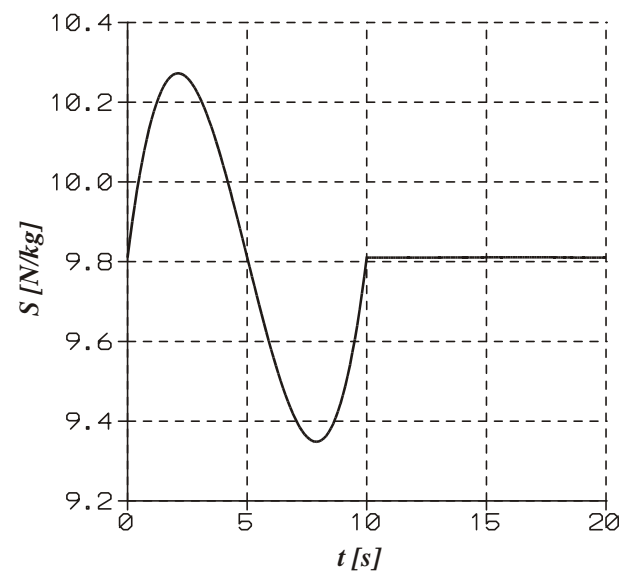

Figure 3e. Change of the optimised values – force in the rope per time

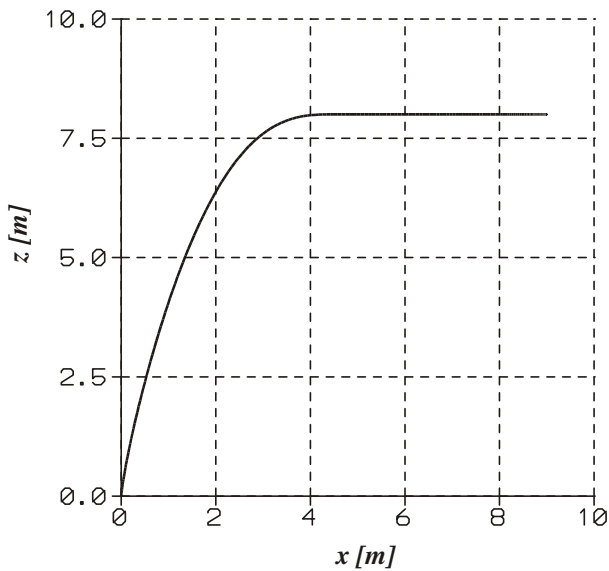

Figure 3f. Change of the optimised values – optimal path of grab and cargo

Values, upon which results shown on Fig. 3a – Fig. 3f are obtained, are: distance between vessel and hopper in x -direction $x_k = 9m$, height distance between beginning/end point of automatic part of half-automatic unloading cycle and discharging point of the grab $z_k = 8m$, $t_c = 20s$ – time, known in advance, needed for obtaining one half of automatic part of half-automatic unloading cycle i.e. grab transfer from vessel to hopper or vice versa, t_c is determined upon maximal allowed velocities and accelerations in x and z direction [6] and $\tau = x^{-1}(x_k/2)$ – time needed for the grab and cargo transfer to one half of distance between vessel and hopper i.e. $z(\tau \leq t \leq t_c) = z_k$.

4 OPTIMAL MOVEMENT OF THE GRAB CRANE DEVICE MECHANISMS – II PHASE OF OPTIMIZATION

4.1 Optimal movement of harbour crane mechanisms

On the basis of previous conception of cargo movement, the link between cargo movement and crane peak movement can be established as:

$$l_1 \cos\varphi + l_2 \sin\theta + l \sin\psi + x - x_k - a = 0$$

$$l_1 \sin\varphi - l_2 \cos\theta - l \cos\psi - z + z_k + b = 0.$$

Respecting that this is a redundancy system, we can deem that change of the rope length l or something else is prominent time function, which generally depends of construction characteristics of the crane. Change of rope length l per time should be determined upon real characteristics of driving mechanisms for specific type of harbour crane, depending of manufacturer. The problem now becomes the direct task of dynamics and unknown momentum's M_A and M_B can be determined from differential equation system (1a) on the basis of obtained optimal cargo movement.

4.2 Optimal movement of the unloading bridge trolley

Due to relatively less complex construction of unloading bridge than harbour crane driving force F_d , needed for trolley movement, can be determined directly from differential equation (1b) on the basis of obtained optimal cargo movement (direct task of dynamics).

The values needed for calculation of the driving force F_d from differential equation (1b) are following: height distance between the beginning/end point of automatic part of half-automatic unloading cycle and rope suspension point $z_t = 17m$, mass of the crane trolley $m_1 = 15000kg$, mass of the grab and cargo $m = 12500kg$. The result is shown on the Fig. 4, while change of the rope length is shown on the Fig. 5.

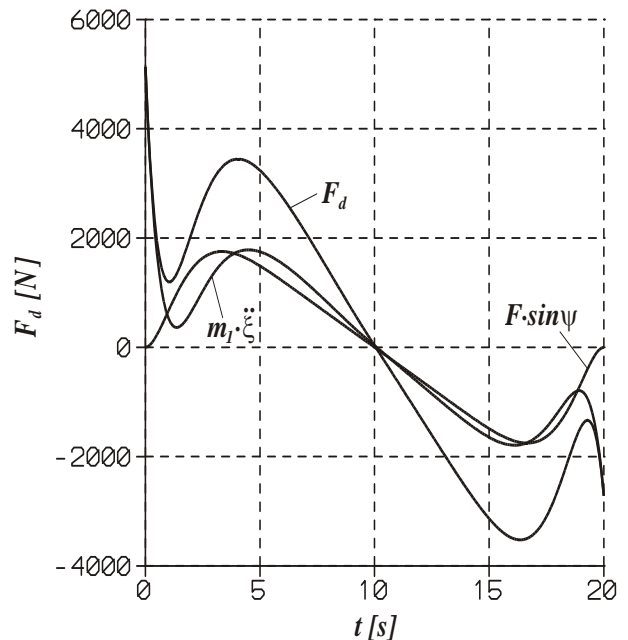

Figure 4. Driving force needed for optimal unloading bridge trolley movement

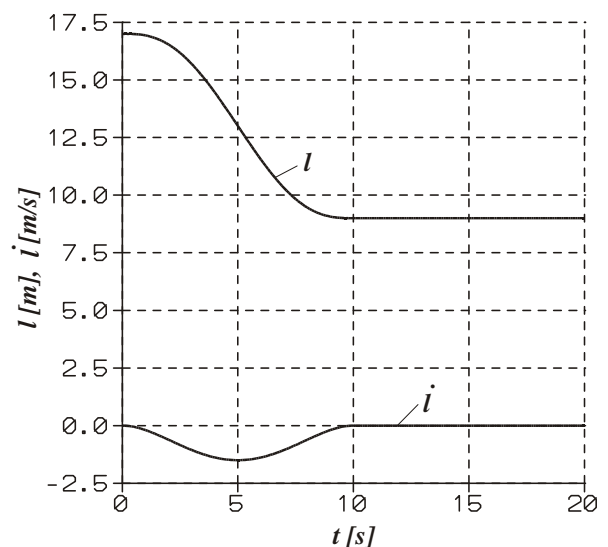

Figure 5. Change of the rope length per time.

5 CONCLUSIONS

Presented two phase optimization procedure replaces complicated non-linear mathematical models of grab crane devices, needed for optimization of the grab and cargo movement, with two relatively simple mathematical models without losing complexity. In the first phase, the general linear model for optimization of grab and cargo movement is developed, while in the second phase relatively complicated non-linear models of crane mechanisms movement (depending on crane construction) are used only for obtaining driving forces or momentum's upon optimal path and parameters of the cargo and grab movement.

Presented procedure allows that complicated non-linear mathematical models of the grab crane devices, needed for optimization of the grab and cargo movement, should be replaced with general linear model of the grab and cargo movement and non-linear model for movement of crane mechanisms without losing any of their complexity.

It is important to underline that developed procedure for optimization of grab and cargo movement has universal application i.e. results of optimization process can be applied on any transport device which can perform such kind of motion (harbour cranes, unloading bridges, overhead cranes etc.).

The characteristic of bulk cargo is the fact that the transport expenses, manipulation and waiting present the important part of their values. Unloading bulk cargo terminal works 24 hours seven days a week during the sailing period. Presented optimized working cycle of grab crane devices reduces rope inclination angle, force in a rope and therefore needed energy for performing such kind of motion.

The application of the results obtained is in introducing of the half automatic unloading cycle during the bulk cargo material unloading. In that case it is possible to achieve the optimal unloading cycle, dissipation of material during the grab discharging can be reduced to the minimum, dynamic strains of cranes can be smaller and it is also possible to eliminate the influence of the human factor in unloading process (training of operator, weather conditions, night work, etc.).

REFERENCES

[1] Oyler, F.J.: Handling of Bulk Solids at Ocean Ports, in: Woehlbier R. H. (Ed.): *Stacking Blending Reclaiming*, Trans Tech Publications, Clausthal, 1977.

- [2] Vuković, J., Bugarić, U., Glišić, D. and Petrović, D.: Optimization of the working cycle of harbour cranes, *Journal of theoretical and applied mechanics*, Vol. 45, No. 1, pp. 147-159, 2007.
- [3] Bugarić, U., Vuković, J., Petrović, D., Jeli, Z. and Petrović, Z.: Optimization of the unloading bridge working cycle, *Journal of Mechanical Engineering - Strojniški Vestnik*, Vol. 55, No. 1, pp. 55-63, 2009.
- [4] Bugarić, U., Tosic S., Vukovic, J. and Brkic, A.: Optimization of Elevator Regimes of Movement, in: *Proceedings of the 11th World Congress in Mechanism and Machine Science*, 01-04.04.2004, Tianjin, pp. 2263-2267.
- [5] Sage, A.P. and White, C.C.: *Optimum System Control*, Prentice-Hall, Eaglewood, 1977.
- [6] Zrnic, Dj., Bugaric, U. and Vukovic, J.: The optimization of moving cycle of grab by unloading bridges, in: *Proceedings of the 9th World Congress on the Theory of Machines and Mechanisms*, 29.08-02.09.1995, Milano, pp. 1001-1005.

ОПТИМАЛНО КРЕТАЊЕ ВИСЕЋЕГ ТЕРЕТА

Угљеша Бугарић, Јосиф Вуковић, Душан
Глишић, Душан Петровић

У раду је приказан један од могућих начина оптимизације кретања висећег терета. Развијена процедура оптимизације је примењена на дизаличне уређаје са грабилицом, као што су претоварни мост и лучка дизалица. Процедура оптимизације је подељена у две фазе. Прва фаза представља оптимизацију кретања грабилице и терета тј. висећег терета. Друга фаза оптимизације састоји се из одрђивања кретања механизма дизаличних уређаја, на основу добијених оптималних путања и параметара кретања грабилице и терета. Облик приказаног математичког модела омогућује директну примену модела теорије оптималног управљања тј. оптимизација кретања висећег терета је изведена применом Понтрјагиновог принципа максимума. Основни циљ оптимизације је постизање минималног радног (истоварног) циклуса, смањење потрошње енергије као и расипања материјала током пражњења грабилице. Сви релевантни изрази су изведени у аналитичком облику.