

PAPER • OPEN ACCESS

Design of electro-mechanical actuator for medium sized helicopter and a test platform for its testing and verification

To cite this article: M Tanaskovi *et al* 2018 *IOP Conf. Ser.: Mater. Sci. Eng.* **393** 012008

View the [article online](#) for updates and enhancements.

Related content

- [Fundamental Consideration of Piezoelectric Ceramic Multi-Morph Actuators](#)
Yoshiro Tomikawa, Koichi Masamura, Sumio Sugawara *et al.*
- [Fast electrochemical actuator](#)
I V Uvarov, A V Postnikov and V B Svetovoy
- [Development of test platform for evaluating disturbance characteristics of a lunar soil sampler](#)
Xingwen Gao, Dewei Tang, Deming Zhao *et al.*



IOP | ebooks™

Bringing you innovative digital publishing with leading voices to create your essential collection of books in STEM research.

Start exploring the collection - download the first chapter of every title for free.

Design of electro-mechanical actuator for medium sized helicopter and a test platform for its testing and verification

M Tanasković¹, M Ristanović², S Stojanović², D Lazić² and M Miloš²

¹Singidunum University, Danijelova 32, Belgrade, Serbia

²University of Belgrade, Faculty of Mechanical Engineering, Kraljice Marije 16, Belgrade, Serbia

E-mail: mtanaskovic@singidunum.ac.rs

Abstract. This paper presents the design of an electro-mechanical actuator that is used for actuation of a medium sized helicopter. The designed actuator consists of a commercially available electro-mechanical cylinder EMC40 from Rexroth Bosch and a brushless DC motor EC45 from maxon motor. Cylinder and the motor are connected by a custom-made gearbox, which allows for their parallel axial mount. In addition to the actuator, the paper describes a test platform that can be used to emulate the forces generated by an actual helicopter. Designed test platform consists of a torsional spring and an AC motor with excentre. Frequency regulator is used to achieve the desired frequency of the force. Experimental results obtained by testing the designed actuator on the test platform are also given in the paper.

1. Introduction

An actuator is an operating device that is used to move a kinematic chain, which in turn allows manoeuvring a system. In this paper we consider actuation of a medium size helicopter whose propeller is actuated by a swashplate (see Figure 1).

Traditionally, helicopter actuators have mainly been pneumatic actuators [1]. However, in recent years, the focus of the industry has shifted more towards electro-hydraulic and electro-mechanical actuators. In electro-hydraulic actuator (see e.g. [5]), the pressure is directly regulated by an electric motor. On the other hand, electro-mechanical actuators consist of electric motor and mechanical parts and do not involve any fluid or gas, which makes them lighter and more suitable for use in aircrafts in which the weight of the parts and the equipment is crucial.

Other advantages that make the use of electro-mechanical actuators in aerospace industry more convenient than the use of traditional hydraulic actuators are safety, financial and environmental issues (for details see e.g. [2], [3] and [4]). Compared to hydraulic and pneumatic systems, electro-mechanical systems need to be powered on only when they are used, which leads to less fuel consumption, which overall reduces the green-house gas emissions. In addition, the inspection time of electro-mechanical actuators is much shorter than the one for hydraulic actuators. Moreover, it is much easier to integrate electronics for self-inspection and failure diagnostics into electro-mechanical actuators. These actuators additionally have longer life cycles and produce less audible noise.

In this paper, we present a design of electro-mechanical actuator that can be used for a medium size helicopter. The actuator consists of commercially available parts, such as an electro-mechanical cylinder from Rexroth Bosch and a brushless DC motor from maxon motor. These two components are connected by a custom-made gearbox that allows their parallel mount.





Figure 1. Helicopter swashplate.

In addition to the actuator, a test platform has been designed that can be used to test its performance under conditions that emulate the conditions on an actual helicopter. Similar test platforms have already been reported in literature (see e.g. [6] and [7]). However, the test platform proposed here is considerably more simple, easier and cheaper to build. It consists of a torsional spring, which on one side has a mount for the actuator under test and on the other side an AC motor with an excentre that can produce sinusoidal force of desired frequency. The test bench is equipped with a torque sensor and a potentiometer, which allows precise measurement of the actuator position and the force that is acting on the actuator.

In the sections that follow, we first describe the design of the actuator, then the design of the test bench and finally, we present the experimental results and give some concluding remarks.

2. Actuator design

We first give the specification of the actuator requirements, we then describe the overall actuator design and finally we present mathematical calculations, which show that the designed actuator satisfies the requirements.

2.1. Actuator requirements

The actuator should be designed such that three such actuators can be used for actuating the swashplate of a medium size helicopter (see Figure 1). Such actuator should be capable of creating linear movement of up to 100 mm. Dynamically, actuator should be capable of making a 25 millimetre move in 0.25 seconds. Moreover, it should be capable of withstanding sinusoidal force with mean value of 600 N, amplitude of 300 N and frequency of 50 Hz.

2.2. Actuator design

The actuator that we propose, in order to meet the described requirements, consists of the following parts:

- Rexroth EMC 40 16 x 5 electromechanical cylinder [8]
- Maxon motor planetary gearhead GP 42 C, P/N: 203113 (reduction 3.5:1) [9]
- Maxon motor brushless DC motor EC45, 250W, P/N: 136210 [10]

The proposed cylinder is based on a spindle with diameter of 16 mm and step of 5 mm with movable nut that uses ball recirculation technology. Due to this technology, the cylinder is capable of generating linear motion with almost no backlash. Main characteristics of the considered cylinder are listed in Table 1.

Considered motor is a brushless DC motor from Maxon motor that has slot-less stator windings. This makes it very compact and capable of achieving very high rotational velocities, as the eddy current losses are very low. In addition, this motor has very low moment of inertia and very high efficiency. Therefore, the selected motor leads to low energy consumption of the actuator and makes it possible to have a compact actuation solution. This is an important factor in making the overall helicopter construction lightweight. Main characteristics of the selected motor are listed in Table 2.

Table 1. Characteristics of the used Rexroth electromechanical cylinder.

Characteristic	Symbol	Value
Spindle diameter	d_{SPIN}	16 [mm]
Step	p_{SPIN}	5 [mm]
Efficiency	μ_{SPIN}	0.9
Maximal input velocity	ω_{SPIN}^{MAX}	6800 [b/min]
Amplification [Nm] into [N]	i_{SPIN}	1256.6 [N/Nm]
Backlash (seen at the output)	$\Delta x_{SPIN}^{BACKLASH}$	0.06 [mm]
Moment of inertia seen at the input	J_{SPIN}	40 [gcm^2]

Table 2. Characteristics of the used maxon DC brushless motor EC 45.

Characteristic	Symbol	Value
Nominal current	I_{MOT}	12.5 [A]
Nominal moment	M_{MOT}	0.311 [Nm]
Maximal speed	ω_{MOT}^{MAX}	12000 [ob/min]
Moment of inertia	J_{MOT}	209 [gcm^2]
Speed-moment characteristic	$\frac{\Delta n}{\Delta M}$	1.98 [ob/min*mNm]
Motor moment constant	k_{MOT}^M	26.3 [mNm/A]
Motor speed constant	k_{MOT}^ω	364 [ob/min*V]

In order to have an actuator that has minimal weight and dimensions, a gear box with transmission of 3.5:1 is used at the motor output. Selected gearbox from maxon motor is quite compact and has a very long life cycle and high efficiency. It is a planetary gearhead with ceramic teeth. This means that the friction between the teeth is smaller and therefore its efficiency is higher and the gearbox lasts longer. Characteristics of the selected gearbox are given in Table 3.

Table 3. Characteristics of the used maxon gearbox GP 42 C.

Characteristic	Symbol	Value
Amplification	i_{RED}	3.5
Efficiency	μ_{RED}	0.9
Maximal input speed	ω_{RED}^{MAX}	8000 [ob/min]
Moment of inertia seen at the input	J_{RED}	14 [gcm^2]
Backlash seen at output	$\Delta \varphi_{RED}^{BACKLASH}$	0.6 [deg]

Table 4. Characteristics of the custom-made gearbox.

Characteristic	Symbol	Value
Amplification	i_{ZUP}	1.4348
Efficiency	μ_{ZUP}	0.7

In addition to the standard parts listed above, the proposed actuator contains also a custom-made gearbox that is used to mount the motor with the maxon gearbox in parallel with the cylinder. The case in which the custom made gearbox is placed also contains the mechanism for mounting the actuator to

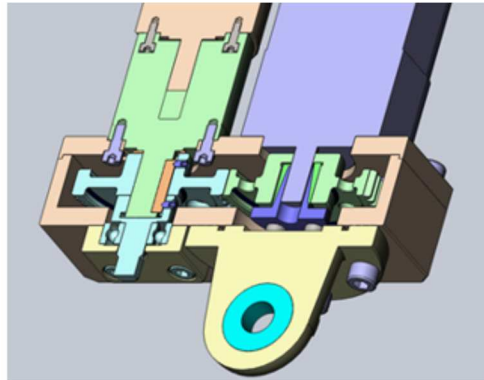

Figure 2. Model of the custom-made gearbox.

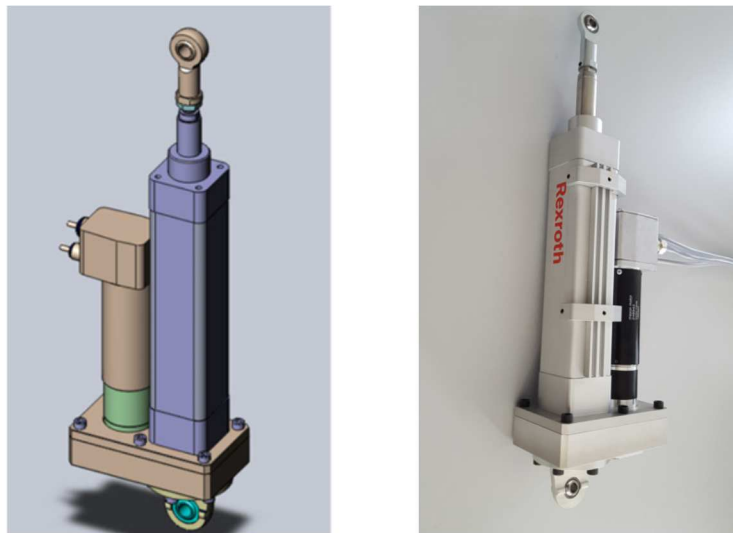

Figure 3. Actuator model (left) and its photo (right).

the fixed surface. Main characteristics of the custom-made gearbox are given in Table 4 and its model is given in Figure 2. Overall model of the designed actuator and its photo are shown in Figure 3.

2.3. Calculation of the actuator characteristics

Nominal force of the actuator can be calculated by multiplying the nominal moment of the used motor with the amplifications and efficiencies of all the parts of the actuator:

$$F_{NOM} = M_{MOT}^{NOM} * i_{ZUP} * \mu_{ZUP} * i_{RED} * \mu_{RED} * i_{SPIN} * \mu_{SPIN} = 941 \text{ N} \quad (1)$$

This nominal force is higher than the RMS of the force that is expected to act on the actuator. Another important feature of the actuator is whether it is capable of making the critical move of 25 mm in 0.25s. In order to calculate this, we first calculate the maximal allowed motor velocity given the maximal allowed input velocities of all the actuator parts:

$$\omega_{MAX} = \min(\omega_{SPIN}^{MAX} * i_{RED} * i_{ZUP}, \omega_{RED}^{MAX}, \omega_{MOT}^{MAX}, \omega_{BRE}^{MAX}, \omega_{SEN}^{MAX}) = 8000 \text{ rpm} \quad (2)$$

Based on this, the maximal linear speed of the actuator can be calculated as:

$$v_{MAX} = \frac{p}{i_{ZUP} * i_{RED} * 60} * \omega_{MAX} = 132 \text{ mm/s} \quad (3)$$

We further assume that during the motion of the actuator, a trapezoidal velocity profile is made (see Figure 4). The maximal acceleration of the trapezoidal motion profile, as well as the acceleration and deceleration time period is calculated as:

$$\Delta t_a = \Delta t_{total} - \frac{\Delta s}{v_{MAX}} = 0.0606 \text{ s} \quad (4)$$

$$a_{max} = \frac{v_{MAX}}{\Delta t_a} = 2178 \text{ mm/s}^2 \quad (5)$$

where $\Delta s = 25 \text{ mm}$ is the travel distance of the actuator and $\Delta t_{total} = 0.25 \text{ s}$ is the maximal time for which the travel has to be made. The acceleration that the motor has to achieve in order for the actuator to reach the required maximal profile acceleration is:

$$\alpha_{MOT} = \frac{2\pi * i_{ZUP} * i_{RED}}{p} * a_{max} = 13744 \text{ rad/s}^2 \quad (6)$$

which is much smaller than the maximal allowed acceleration of the selected motor. In order to calculate the maximal moment of the motor required to make this motion profile, we first calculate the total moment of inertia seen by the motor.

$$J_{total} = J_{MOT} + J_{BRE} + J_{SEN} + J_{RED} + \frac{J_{SPIN}}{i_{RED}^2} + \frac{m_{load}}{i_{RED}^2 * i_{SPI}^2} = 237 \text{ gcm}^2 \quad (7)$$

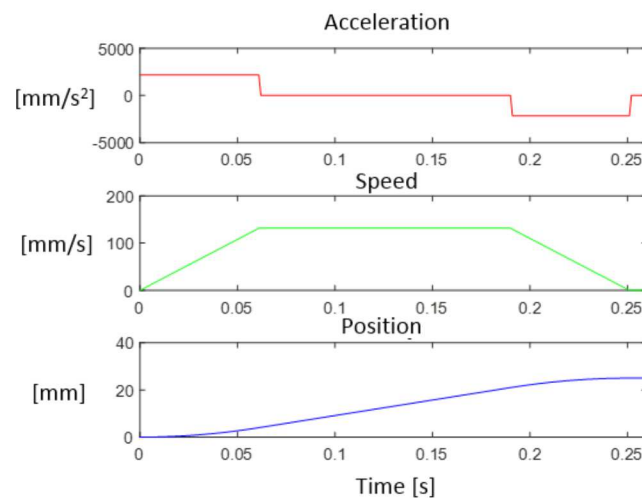

Figure 4. Motion profile of the actuator.

Based on this, the maximal moment that the motor should have in order to generate required acceleration, while at the same time counteracting the maximal force of the external force profile can be calculated as:

$$M_{MAX} = 1000 * \left(\frac{F_{MAX}}{i_{ZUB} * i_{SPIN} * i_{RED} * \mu_{ZUB} * \mu_{SPIN} * \mu_{RED}} + \frac{J_{total} * \alpha_{MAX}}{1000 * 100^2} \right) = 661.1 \text{ mNm} \quad (8)$$

Selected motor can achieve this maximal required moment with no problem.

3. Test bench for actuator verification

In order to verify the performance of the designed actuator and to emulate the forces that it would experience on a real helicopter, a test bench has been designed. The test bench is placed on a table that allows easy mounting of the tested actuator. The bench consists of a torsional spring with the actuator

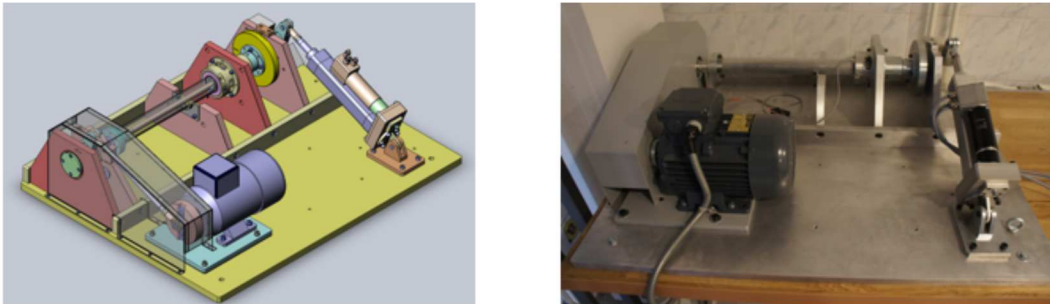

Figure 5. Test platform for actuator verification model (left) and its photo (right).

mounting mechanics on one side and an AC motor with excentre on the other. The model of the designed test platform and its photo are given in Figure 5.

The force acting on the actuator can be regulated by a frequency regulator, which governs the rotation of the AC motor. In addition, the platform is equipped with precise torque and position sensor, whose readings are collected by a custom made acquisition software.

4. Experimental results

For the purpose of testing the performance of the designed actuator, the brushless DC motor has been controlled with the maxon EPOS 2 70/10, which is a driver suitable for the selected motor [11]. In the tests, the driver was set to the position mode. The first test that has been done is the test of the actuator dynamic characteristic. In particular, a step reference change of 0.25 mm has been given to the driver and the time response of the actuator has been recorded. Results of this test are shown in Figure 6.

Additionally, a test which shows the reaction of the actuator on the external force has been done. In this test, the AC motor on the test bench has been regulated such that sinusoidal force with the mean of

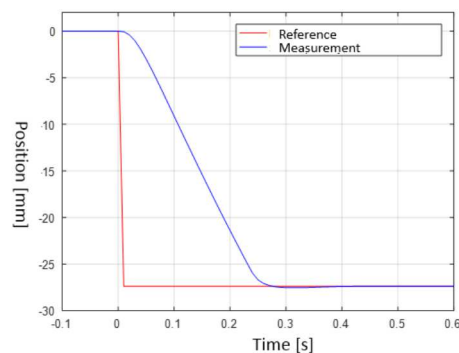

Figure 6. Result of the actuator dynamical test.

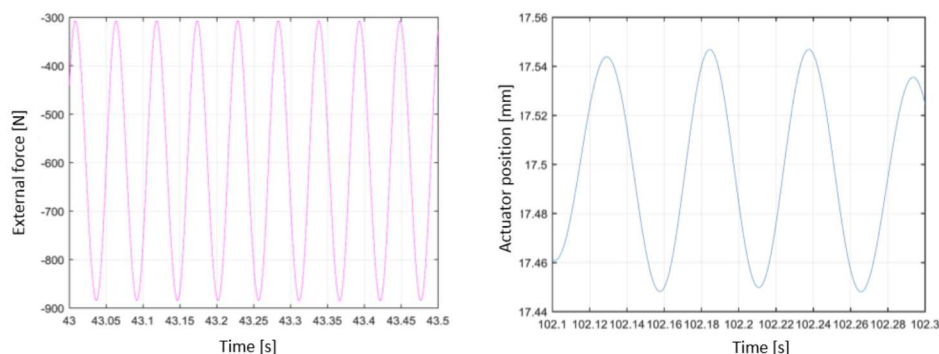

Figure 7. Result of the static actuator test. External force profile (left) and the resulting actuator position (right).

600N, amplitude of 300N and frequency of 50 Hz. The actuator is regulated so that it keeps its position in a given position despite the sinusoidal change of the force. Obtained results are shown in Figure 7. As can be seen, the designed actuator behaves very well both in the dynamic and in the static tests. Therefore, the experiments on the test bench demonstrate that the designed actuator is suitable for the actuation of a medium size helicopter.

5. Conclusion

This paper presents a novel design of an actuator that can be used for actuating a swash plate of a medium size helicopter. The designed actuator consists mainly of commercially available parts. It is made of electro-mechanical cylinder from Rexroth, brushless DC motor and gearbox from maxon motor and a custom made gearbox, which makes it possible to mount the electromechanical cylinder on one side and a system consisting of electro motor and gearbox parallel to it on the other side. The designed actuator is well suited for the purpose of actuating a medium size helicopter, as shown by experiments on the designed test platform.

Acknowledgments

Authors would like to thank Mr. Milan Milisavljević, Dipl.-Ing. for his contribution.

References

- [1] Echevarria I, Lasa J, Casado P, Domingez A, Eguizabel I, Lizeaga M, Perez R and Berenguer O 2015 *Test Bench for Helicopter Electro Mechanical Actuation System Validation: Design and Validation of Dedicated Test Bench for Aeronautical Electromechanical Actuators*, IEEE International Conference on Industrial Technology ICIT, Seville, Spain, March 17-19, pp. 517-523
- [2] Shaw J C, Fletcher S D A, Norman P J and Galloway S J 2012 *More Electric Power System Concepts for an Environmentally Responsible Aircraft (N+2)*, 47th International Universities Power Engineering Conference UPEC, London, UK, September 4-7, pp. 1-6
- [3] Villani M, Tursini M, Fabri G and Castellini L 2012 High Reliability Permanent Magnet Brushless Motor Drive for Aircraft Application, *IEEE Transactions on Industrial Electronics* **59**(5) 2073-2081
- [4] Garcia A, Cusido I, Rosero J A, Ortega J A and Romeral L 2008 Reliable Electro Mechanical Actuators in Aircraft, *IEEE Aerospace and Electronic Systems Magazine* **23**(8) 19-25
- [5] Altare G, Vacca A and Richter C 2014 *A Novel Pump Design for an Efficient and Compact Electro-Hydraulic Actuator*, IEEE Aerospace Conference, Big Sky, MT, USA, March 1-8. pp. 1-12
- [6] Bester J E, Mabwe A M and El Hajjaji A 2015 *A Virtual Electrical Test Bench for More Electrical Aircraft Architecture Verification And Energy Management Development*, 17th European Conference on Power Electronics and Applications EPE, Geneva, Switzerland, September 8-10, pp. 1-10
- [7] Ciancetta F, Rotondale N, del Pizzo A and Nardi M 2013 *Development of a Measurement System to Test the Efficiency of Electrical Generators for Energy Recovery on Aircraft Actuators*, International Conference on Clean Electrical Power ICCEP, Alghero, Italy, June 11-13, pp. 564-570
- [8] Rexroth Bosch, *User Manual (Electro-Mechanical Cylinder EMC 40, 16x5)*, <http://www.yij.tw/templates/cache/24517/images/5513ab8851f75.pdf>
- [9] Maxon motor, *User Manual (Planetary gearhded GP 42 C)*, https://www.maxonmotor.com/medias/sys_master/root/8825117769758/17-DE-345-346-347.pdf
- [10] Maxon motor, *User Manual (Brushless DC motor EC45, 250W)*, https://www.maxonmotor.com/medias/sys_master/root/8824958320670/17-DE-221.pdf
- [11] Maxon motor, EPOS2 70/10 Driver, User Manual, https://www.maxonmotor.com/medias/sys_master/root/8825243795486/17-DE-431-432-433-435.pdf